

REV.	SPECIFICATION	ECN NO.	APPD.

Male:

Female:

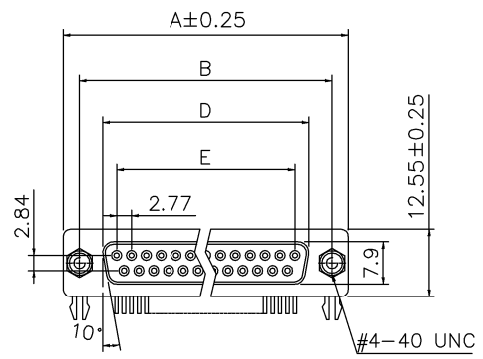
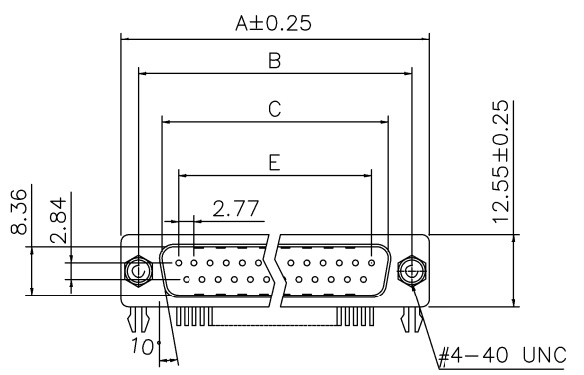

Material:

Housing: PBT, UL94V-0.
Contacts: Brass, Gold Plated on Contact Area and Gold Flash on Solder Tail over Nickel 50u".
Shell: Steel, 60u"Nickel Plated over 50u"Copper.
Boardlock: Steel, Tin Plated.
Screwlock: Steel, Nickel Plated.
Electrical Characteristics:
Current Rating: 3 AMP.
Dielectric Withstanding Voltage: AC 1000V .
Insulation Resistance: 1000MΩ min..
Contact Resistance: 20mΩ max.
Operating Temperature: -55°C~+105°C.
***RoHS Compliant**

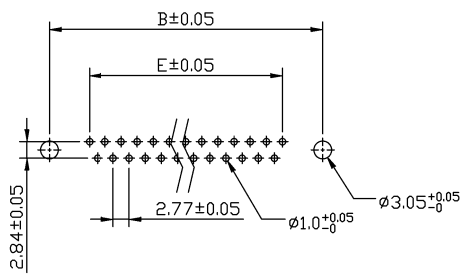
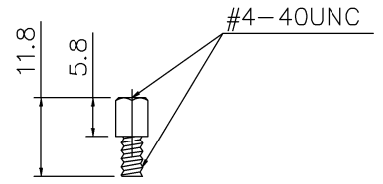
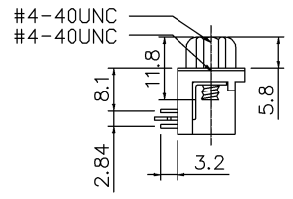
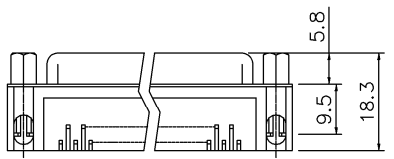
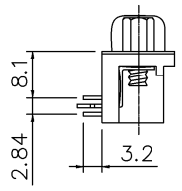
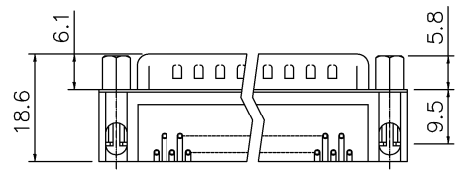

Series 7906-A xx x A A -6MM

Positions Bolthead Length

M:Male A:Tray Package

F:Female A:With Grounding Forks and With Jack Screws Attached

#4-40 unc screwlock installed

Dimension					
Positions	A	B	C	D	E
09	30.81	24.99	16.92	16.33	11.08
15	39.20	33.30	25.25	24.70	19.39
25	53.05	47.04	38.96	38.40	33.24
37	69.40	63.50	55.42	54.80	49.86

Tolerances	Dwg No.	7906D03033
x. = ±0.38	Projection	
.x = ±0.25	Unit	mm
.xx = ±0.13	Scale	1:N
	Drawn By	Martin 04/10'23

Title: 7906-A Series
D-SUB
Right Angle Type

OUPIIN
OUPIIN ELECTRONIC(KUNSHAN) CO., LTD.
P/N: 7906-AxxMAA-6MM&7906-AxxFAA-6MM

SHEET	1/1	Ver.No.	A1
-------	-----	---------	----

⑦ 747