



PRODUCT SPECIFICATION

產品規格書

產品名稱 Description	產品料號 Part No.	圖號 Drawing No.
Hybrid Power Low Profile Edge Card Connector	9392-4PxxSxxx1xC(B)xxDx	9392-D0000-xxx
	9392-4SPxxSxxx1xC(B)xxDx	9392-D0000-xxx
	9392-4SS24P08x1xC(B)xxDx	9392-D0000-xxx

PRODUCT NAME 產品名稱	DOCUMENT No.: 文件編號	Rev. 版本	OUPIIN
Hybrid Power Low Profile Edge Card Connector	Q9392-PSS-006	G	歐品電子
	Approved 核准	Checked 審核	Prepared 制作



PRODUCT SPECIFICATION OF Oupiin

1. SCOPE 適用範圍

This product specification defines the product performance and the test methods to ascertain the performance of the Hybrid Power Low Profile Edge Card Connector , which is designed and manufactured by Oupiin Electronic Co., Ltd. This product specification is applicable but not only for those part numbers which be shown in the cover page.

本產品規格書規定了由歐品電子有限公司設計生產的Hybrid Power Low Profile Edge Card Connector型連接器產品的特性及測試方法。本產品規格書適用於但不局限於封面所顯示的產品料號。

2. REFERENCE DOCUMENTS 參考文件

MIL-STD-1344	Test method for electrical connector 電子連接器測試方法
MIL-STD-202	Test method for electrical components 電子零件測試方法
EIA364	Test method for electrical components 電子零件測試方法
JIS C 0051	Test method for electrical components 電子零件測試方法
MIL-G-45204C	Specification for gold plating 鍍金規格
IEC-512-3	IEC standard for current carrying capacity tests IEC電流測試標準
QQ-N-290A	Specification for nickel plating 鍍鎳規格
MIL-P-81728A	Specification for tin/lead plating 鍍錫鉛規格
MIL-T-10727B	Specification for tin plating 鍍錫規格
UL1977	UL standard for safety of attachment plug and receptacle UL安規要求標準

3. FEATURE & DIMENSIONS 特征及尺寸

3.1. PRODUCT DIMENSION 產品尺寸

These connectors shall have the dimensions as shown in drawing.

本產品的相關尺寸參見圖面。

3.2. MALE AND FEMALE PRODUCT 公母產品裝配

3.2.1. Male Female assembly dimension 公母產品裝配尺寸

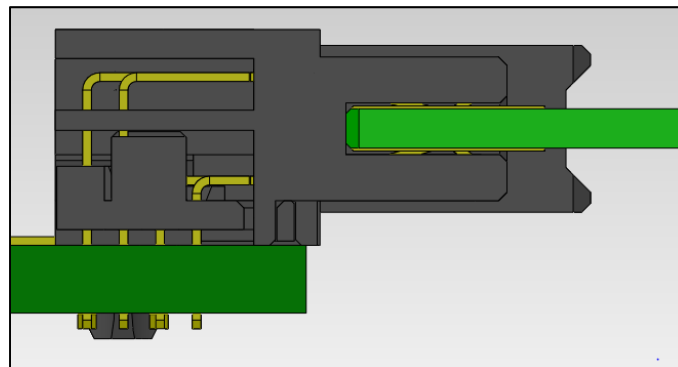

If female Type is Edge Card , While distance between male's PCB and female's PCB is not accurate requisition 如是插卡類型，公母PCB板之間的尺寸不做準確要求

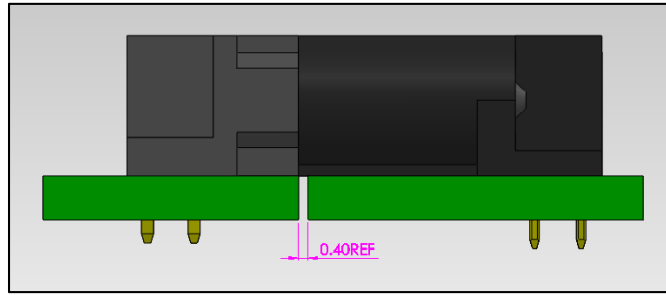

Distance between male's PCB and female's PCB is 0.40REF

公母PCB板之間的尺寸為0.40REF

3.2.2 Perpendicular to engaging direction 垂直插入方向

the design of the centering and guiding in the Mpc of the free and fixed board connector modules shall accept a misalignment of 1.83mm in transverse and 1.425mm in longitudinal axes of the connector
 固定板連接器模件的Mpc裡，連接器設計中心線橫向可接受1.83mm和縱向可接受1.425mm的偏差。

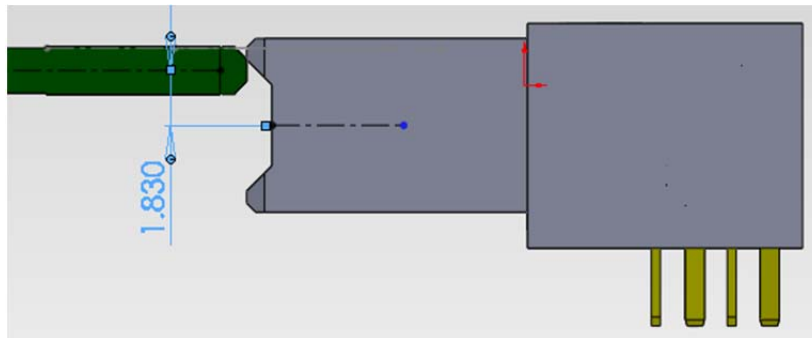

allowed misalignment in transverse axes 在橫向方向允許對插偏差量

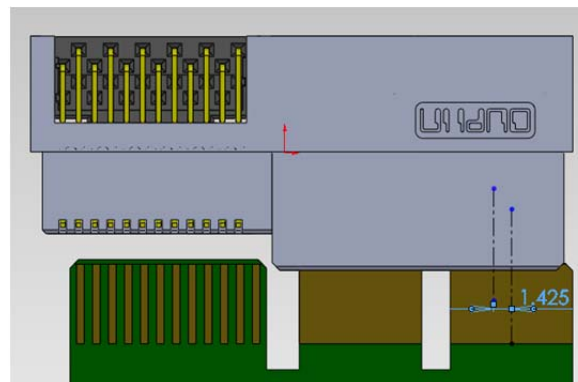

allowed misalignment in longitudinal axes 在縱向方向允許對插偏差量

3.2.2 inclination 傾向

The center and guiding in the Mpc of the free and the fixed board connector modules shall allow an initial angular misalignment of 2° from both the transverse and longitudinal axes
 固定板連接器模件的在Mpc裡,連接器可接受橫向和衝向2° 的最大傾斜對插角度。

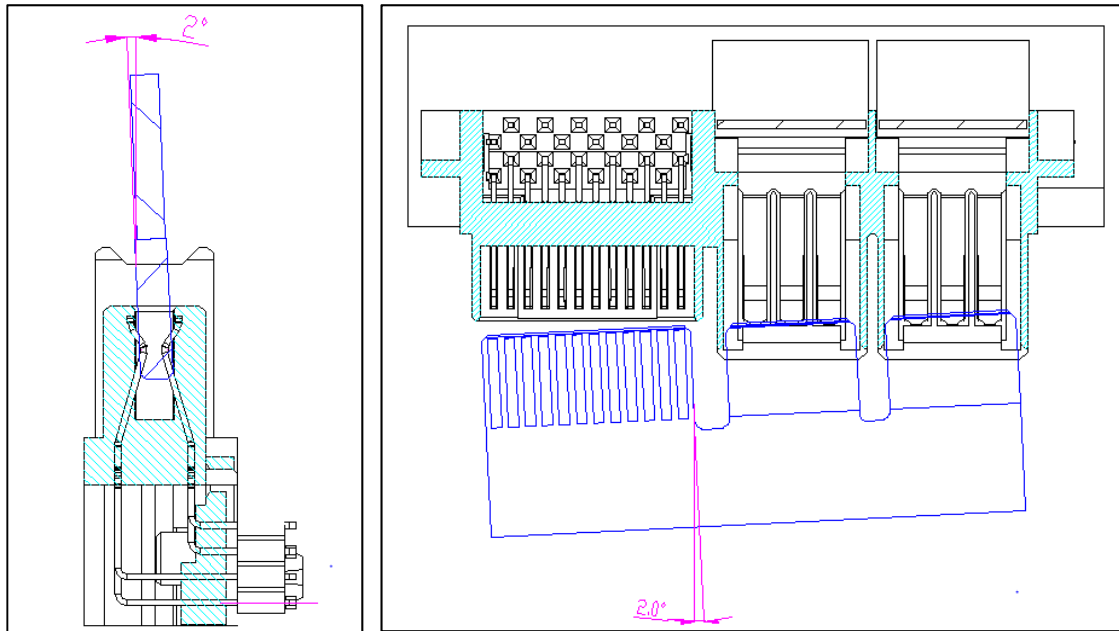

3.2.3 Capability for products wipe length

產品接觸長度等級

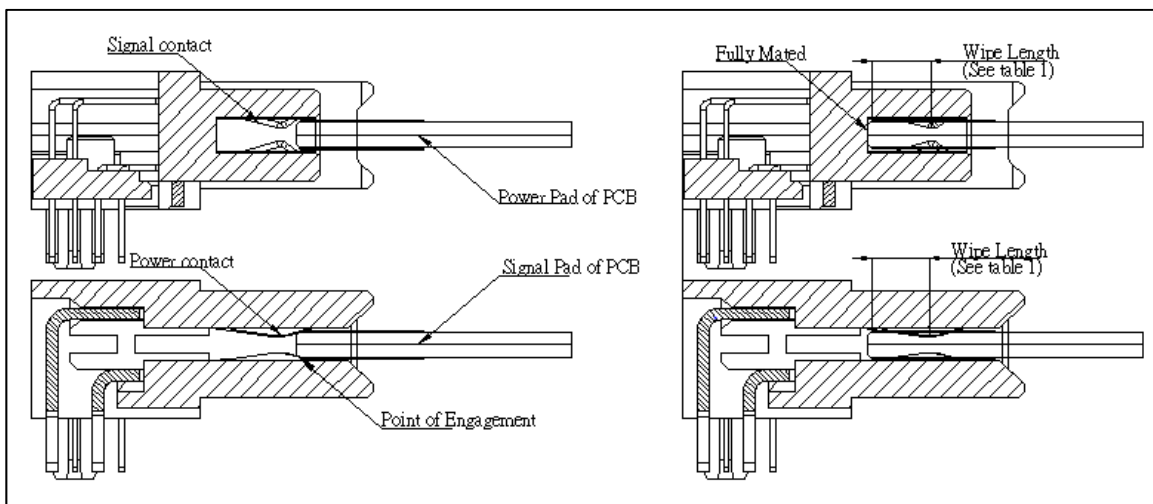

CONTACT	MATING LEVEL	WIPE LENGTH(MIN)
Power Pin	1	2.97mm
	2	1.47mm
Signal Pin	1	1.57mm
	2	2.57mm

3.3. PCB/PANEL LAYOUT 印刷電路板佈局

The recommended PCB layout is shown in drawing.

本產品適用的 PCB layout 參見圖面。



PRODUCT SPECIFICATION OF Oupin

3.4. BILL OF MATERIAL 材料清單

Harmful material controlling follows the requirements of RoHS. The bill of material is described in drawing.

有害物質控制符合RoHS指令要求。本產品使用的材料參見圖面。

3.5. MECHANICAL & ELECTRICAL CHARACTERISTIC 機械及電氣特性

The connector shall have the mechanical and electrical performance as described in drawing.

本產品的機械及電氣特性參見圖面。

3.6. PACKAGING 包裝

Products shall be packaged according to requirements specified in purchase order for safe delivery, connector container and the packaging method are shown in package specification.

產品可依客戶指定要求包裝，包裝材料與包裝方式參見產品包裝規範。

3.7. RATING CURRENT, RATING VOLTAGE AND TR 額定電流,額定電壓及溫升

Rating current: 額定電流

	Rating Voltage	Rating Current
Power Contacts	250V AC	60A(UL)
Signal Contacts	30V DC	1A

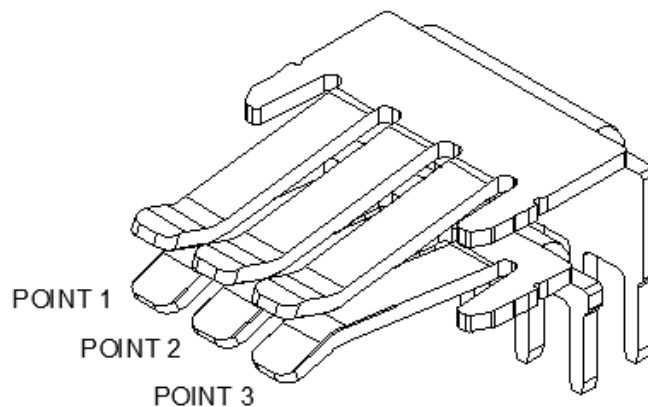

One Circuit

3.8 TEMPERATURE RISE 溫升

1.Chart of Temperature vs current(series connection with all contact of SPEC)

加載電流對應溫度曲線圖(相同規格的所有 PIN 串聯起來)



PRODUCT SPECIFICATION OF Oupin

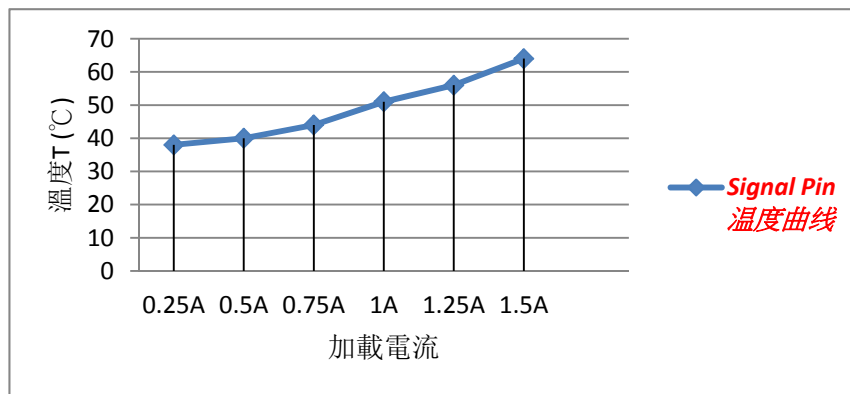
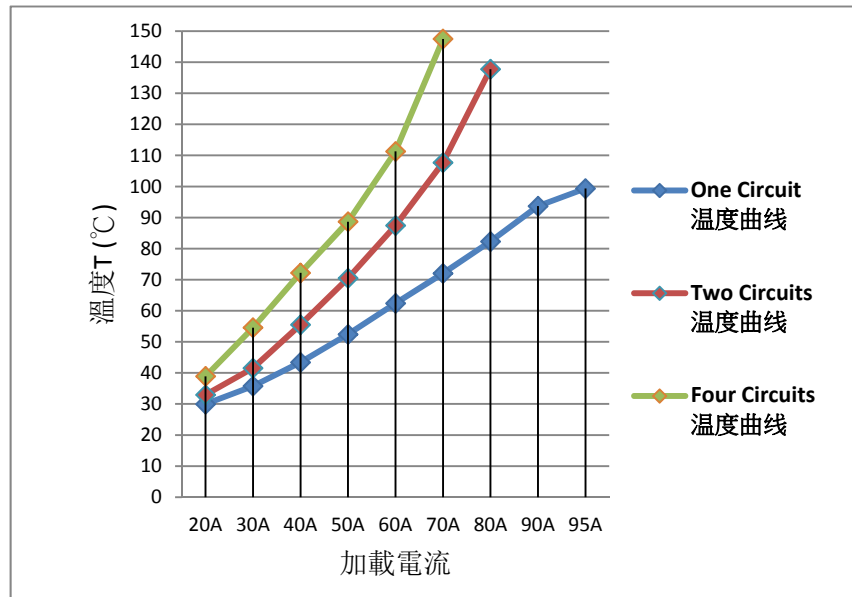

3.9 STORAGE AND OPERATING TEMPERATURE 存貯與使用溫度

Temperature range: $-40^{\circ}\text{C}\sim+105^{\circ}\text{C}$, including terminal temperature rise for rating current.

Storage Temperature: $0^{\circ}\text{C}\sim+40^{\circ}\text{C}$, Humidity: 80%RH under, Time limit is 12 months the products are stored.

溫度範圍： $-40^{\circ}\text{C}\sim+105^{\circ}\text{C}$,包含接觸端子的額定電流溫升。

儲存溫度： $0^{\circ}\text{C}\sim+40^{\circ}\text{C}$ ，濕度：80%RH以下，產品限存時間為12個月。

4. ENVIRONMENTAL (環境要求)

4.1. SOLDERABILITY (可焊性)

Connectors meet solder ability to EIA-364-52. Finish shall be free of contaminants.

(產品可焊性符合 EIA-364-52 標準規定的相關要求，表面不得有污染物。)

4.2. RESISTANCE TO SOLDER HEAT (耐焊接熱)

4.2.1. INFRARED REFLOW 紅外線回流焊接

Each cycle consists of three consecutive phases, as shown in **Table III**.



PRODUCT SPECIFICATION OF Oupin

每個焊接週期包括三個連續的階段，見附表三。

4.3. WAVE SOLDER 波峰焊接

Each cycle consists of three consecutive phases, as shown in **Table IV**.

每個焊接週期包括三個連續的階段，見附表四。

Note: 說明

Device temperature measurements are referenced from the top-center of the package outer surface.

設備溫度量測時以從頂部中間位置測量為準。

5. PERFORMANCE AND TEST DESCRIPTION 性能及測試

5.1. REQUIREMENT 要求

Product is designed to meet electrical, mechanical, and environmental performance requirements specified in **Table I**.

本產品設計符合附表一所列的機械，電氣及環境要求。

5.2. TEST CONDITION 測試條件

Unless otherwise specified, all tests shall be performed at ambient environmental conditions.

除非特別注明，所有測試在室溫條件下完成。

5.3. SAMPLE SELECTION 樣品選擇

Test samples shall be selected at random from current production. No test samples shall be reused. Samples are pre-conditioned with 10cycles of durability. Each group shall be containing 5 test samples at least.

測試樣品從現生產的產品中隨機抽取，所有測試過的樣品不得重複使用。樣品已預先插拔10次，每組測試至少有5個樣品。

5.4. TEST SEQUENCE 測試順序

Product qualification test sequence as shown in **Table II**.

產品品質測試順序見附表二。



Table I: Test Requirements and Methods

附表一：測試要求與方法

Items 項目	Requirements 要求	Test Methods 測試方法
1. Confirmation of Product 產品確認	Product shall be conforming to the requirements of applicable product drawing. 產品必須符合相關產品圖面的要求。	Visually, dimensions and functionally inspected per applicable product drawing. 依相關產品圖面，檢查產品的外觀、尺寸及功能。
2. Contact Resistance 接觸阻抗	Power pin: 5.0mΩ Max initial. Signal pin: 20.0mΩ Max initial. Power pin 初始狀態 5.0mΩ Max Signal pin 初始狀態 20.0mΩ Max Per EIA 364 TP06 適用：EIA 364 TP06	Subject mated contacts assembled in housing to closed circuit of 20 mA max.所述固定端子連結到一個封閉回路中測試,電流 20 mA max,電壓 20 mV max。
3. Insulation Resistance 絕緣阻抗	Power Pin: 10000 MΩ Min. Signal pin: 500 MΩ Min. Power Pin: 最小 10000 MΩ. Signal pin: 最小 500 MΩ. Per EIA 364-21 TP06 ,Condition B 適用：EIA 364 -21TP06,條件 B	Measure by applying test potential between the adjacent contacts, and between the contacts and ground in the mated connector. (500 V DC±10%). 測試產品相鄰端子間以及端子與接地間的電阻 (500 V DC±10%)。
4. Dielectric Withstanding Voltage 耐電壓	Power pin must withstand test potential of 1500VDC for 1 minute, current leakage must be 1.0mA Max. Signal pin must withstand test potential of 1500VDC for 1 minute, current leakage must be 1.0mA Max. Power pin 必須承受測試電壓 1500 VDC，時間 1 分鐘，漏電流不大于 1.0 mA Signal pin 必須承受測試電壓 1500 VDC，時間 1 分鐘，漏電流不大于 1.0 mA Per EIA-364-20 適用：EIA-364-20.	Measure by applying test potential between the adjacent contacts, and between the contacts and ground in the mated connector. 對產品相鄰端子間以及端子與接地間加載電壓，並測試其漏電流。



PRODUCT SPECIFICATION OF Oupin

<p>5. Durability (Repeated Mating/Un-mating) 耐久性</p>	<p>After testing :Maximum Change: Signal Contact: 15 milliohm , Power Contact: 0.75 milliohm 初始狀態最大 20 mΩ。測試後：信號 PIN 最大變化 15mΩ; 電源 PIN 最大變化 0.75mΩ</p> <hr/> <p>Per EIA-364-09 適用：EIA-364-09</p>	<p>Repeat mate and unmated for connector 250 cycles, at a speed of 25.4 mm per minute. 重復進行配合產品 250 次插拔，速度 25.4mm/分鐘。</p>
<p>6. Contact Retention Force 端子保持力</p>	<p>Power pin: 1.0kgf /Pin. Min. Signal pin: 0.3kgf /Pin. Min. Power pin 每支最小 1.0kgf Signal pin 每支最小 0.3kgf</p>	<p>Apply axial pull out force at a speed of 25.4±3 mm/minute on the contact assembled in the housing. 以 25.4±3mm/分鐘的速度施加軸向拉力從塑膠本體上拔出端子。</p>
<p>7. Mating /Un-mating Force 插入力/拔出力</p>	<p>Power pin: Mating force: 700g/pin Max. Un-mating force:150g/pin Min Signal pin: Mating force: 110g/pin pair Max. Un-mating force:15g/pin pair Min Power pin: 插入力最大: 700g /pin Max 拔出力最小: 150g/pin Min Signal pin: 插入力最大: 110g /pin pair Max 拔出力最小: 15g/pin pair Min</p>	<p>At a speed of 25.4±3 mm/minute, apply axial insert the mating part into fully or pull out from the subject product. 以 25.4±3 mm/分鐘的速度，軸向完全插入對配插件到被測產品中或從被測產品中拔出。</p>
<p>8. Vibration 機械振動</p>	<p>After testing, no damage. No electrical discontinuity greater than 1μs shall occur, Contact Resistance: Maximum Change: Signal Contact: 15 milliohm Power Contact: 0.75 milliohm. 測試後，產品无损坏.不允許出現超過 1μs 的瞬間斷開，接觸阻抗信號 PIN 最大變化 15mΩ;電源 PIN 最大變化 0.75mΩ。</p> <hr/> <p>Per EIA-364-28. 適用：EIA-364-TP-28。</p>	<p>Subject mated connector to 10-55-10 Hz traversed in 1 minute at 1.5mm amplitude, 15 minutes each of 3 mutually perpendicular planes, 10-55-10 Hz,振幅 1.5 mm 條件下，在互相垂直的三個面上，每個面 15 分鐘下測量，電流 10 mA。</p>



PRODUCT SPECIFICATION OF Oupin

<p>9. Thermal Shock 溫度沖擊</p>	<p>After testing, no damage, Maximum Change: Signal Contact: 15 milliohm Power Contact: 0.75 milliohm. Dielectric Strength should be OK, Insulation Resistance Power Pin should be 1000 MΩ Min ,Signal Pin should be 500 MΩ Min.</p> <p>測試後產品無損壞，接觸阻抗: 接觸阻抗信號PIN最大變化15.0mΩ; 電源PIN最大變化0.75mΩ; 耐電壓測試OK，絕緣阻抗電源PIN最小1000 MΩ, 信號PIN最小500 MΩ。</p>	<p>Temperature range from -55°C to +105°C. Start from -55°C, after 30 minutes, change to +105°C; change time is no more than 5 minutes, total 5 cycles.</p> <p>溫度變化範圍： -55°C~ +105°C。從 -55°C 開始，30 分鐘後換到+105°C，轉換時間不超過 5 分鐘，共 5 個循環。</p>
<p>10. Humidity- Temperature Cycle 溫濕度循環</p>	<p>After testing, no damage, Maximum Change: Signal Contact: 15 milliohm Power Contact: 0.75 milliohm. Dielectric Strength should be OK, Insulation Resistance Power Pin should be 1000 MΩ Min ,Signal Pin should be 500 MΩ Min.</p> <p>測試後產品無損壞，接觸阻抗: 接觸阻抗信號 PIN 最大變化 15mΩ; 電源 PIN 最大變化 0.75mΩ; 耐電壓測試 OK，絕緣阻抗電源 PIN 最小 1000 MΩ, 信號 PIN 最小 500 MΩ。</p>	<p>Subject product to 25~65°C, 50-80%.R.H 24Cycles.</p> <p>產品置於 25~65°C,相對濕度：50-80%,循環 24 次,</p>
<p>11. Test temperature rise for rating current 溫升測試</p>	<p>The test temperature above ambient shall not exceed RTI(130°C) for UL.</p> <p>测试溫度不能超過 UL 标准的 RTI(130°C)值.</p> <p>Ambient conditions - Still air 25°C。</p> <p>周圍環境溫度 25°C。</p>	<p>Subject mated contacts assembled in housing to closed circuit of Power Pin: 60A max, 250V max, Test Specification</p> <p>所述固定在外殼包的端子連結到一個封閉回路中測試，Power Pin:60A max, 250Vmax。</p>
	<p>Per EIA-364-70 適用：EIA-364-70</p>	



PRODUCT SPECIFICATION OF Oupin

<p>12. Salt Spray 鹽霧</p>	<p>After testing, no damage, Maximum Change: Signal Contact: 15 milliohm Power Contact: 0.75 milliohm. Dielectric Strength should be OK, Insulation Resistance Power Pin should be 1000 MΩ Min ,Signal Pin should be 500 MΩ Min. 測試後產品無損壞，接觸阻抗：接觸阻抗信號 PIN 最大變化 15.0mΩ;電源 PIN 最大變化 0.75mΩ；耐電壓測試 OK，絕緣阻抗電源 PIN 最小 1000 MΩ, 信號 PIN 最小 500 MΩ。</p> <p>Per EIA-364-26 適用：EIA-364-26</p>	<p>5±1% salt concentration(PH=7.0) ,48 hours 35±2°C:. 鹽水濃度 5±1%(PH=7.0),時間 48 小時，溫度 35±2°C。</p>
<p>13.High Temperature Life 高溫老化</p>	<p>After testing, no damage, Maximum Change: Signal Contact: 15 milliohm Power Contact: 0.75 milliohm. Dielectric Strength should be OK, Insulation Resistance Power Pin should be 1000 MΩ Min ,Signal Pin should be 500 MΩ Min. 測試後產品無損壞，接觸阻抗：接觸阻抗信號 PIN 最大變化 15mΩ; 電源 PIN 最大變 0.75mΩ; 耐電壓測試 OK，絕緣阻抗電源 PIN 最小 1000 MΩ, 信號 PIN 最小 500 MΩ。</p> <p>Per EIA-364-17 Method A 適用：EIA-364-17，條件 A。</p>	<p>Subject product to 105°C for 180 hours continuously. 產品置於 105°C 連續 180 小時。</p>
<p>14. Solder-ability 可焊性</p>	<p>Appearance of the specimen shall be inspected after the test with the assistance of a magnifier capable of giving a magnification of 10 X for any damage such as pinholes, void or rough surface. 5% maximum dewetting.- 產品在測試完成後，在放大倍數為 10 倍的顯微鏡下，檢查外觀損壞如：小孔，空焊，外觀粗糙度。 未沾錫區不大於 5%</p> <p>Per EIA-364-52 適用：EIA-364-52</p>	<p>Solder-bath temperature 245±5°C , duration 5 sec. 錫爐溫度為 245±5 度，沾錫時間 5 秒</p>



Table II: Product Qualification Test Sequence

附表二：產品測試順序

Test Description 測試描述	Test Group 測試分組									
	A	B	C	D	E	F	G	H	I	J
1. Conformation of Product 產品確認	1,7	1,3	1,9	1,9	1,9	1,9	1,9	1,9	1,9	1,3
2. Contact Resistance 接觸阻抗	2,6		2,6	2,6	2,6	2,6	2,6	2,6	2,6	
3. Insulation Resistance 絕緣阻抗	3		3,7	3,7	3,7	3,7	3,7	3,7	3,7	
4. Dielectric Withstanding Voltage 耐電壓	4		4,8	4,8	4,8	4,8	4,8	4,8	4,8	
5. Durability 耐久性	5									
6. Contact Retention Force 端子保持力		2								
7. Mating/Un-mating Force 插入/拔出力			5							
8. Vibration Sinusoidal Low Frequency 低頻正弦振動				5						
9. Thermal Shock 溫度衝擊					5					
10. Humidity-Temperature Cycle 溫濕度循環						5				
11. Current rating 溫升測試							5			
12. Salt Spray 鹽霧								5		
13. High Temperature Life 高溫老化									5	
14. Solder-ability 可焊性										2

Table III: Reflow Soldering Profile

附表三：回流焊接曲線圖

Lead-free reflow profile requirements:

無鉛回流焊接曲線

Parameter 参数	Reference 参考	Specification 规格
升溫區 Ramp-up	25°C ~150°C	3°C /S Max
預熱區(Pre-heating) Temperature Min($T_{s_{min}}$) Temperature Max($T_{s_{max}}$) Time($T_{s_{min}}$ to $t_{s_{max}}$)	150°C ~200°C	60~180sec
Time maintained above(保持时间) Temperature(T_L) Time(t_L)	217°C	60~150sec
Time within 5°C of actual peak Temperature(t_p)	260-/+5°C	20~40sec
冷卻區 Cooling	Ramp-Down Rate	6°C /S(Max)
Time 25°C to Peak Temperature	25°C ~ Peak Temp.	8 minutes maximum

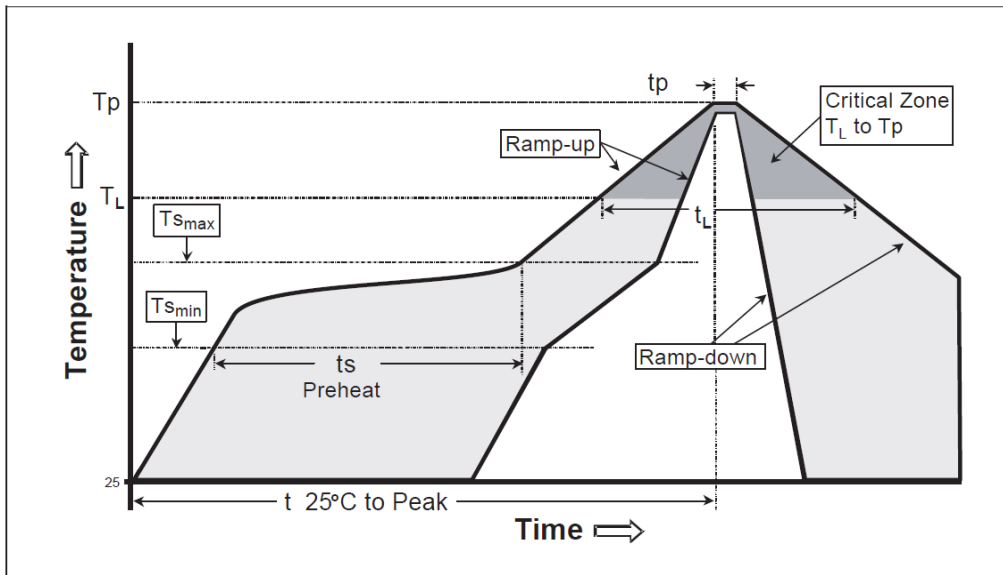

This profile is the minimum requirement for evaluating soldering heat resistance of components .Heat transfer method used for reflow soldering is hot air convection .The actual air temperatures used to achieve the specified profile largely dependent on the reflow equipment.

這個曲線圖是評估元件器件焊接抗熱的基本要求。應用在對焊接中的熱傳遞方式是熱氣對流。達到特定曲線圖地實際溫度主要依賴與回流焊接設備。

Table IV : Weld the curve graph in crest

附表四：波峰焊曲線圖

