

| | | | |
|------|---------------|---------|-------|
| REV. | SPECIFICATION | ECN NO. | APPD. |
| | | | |

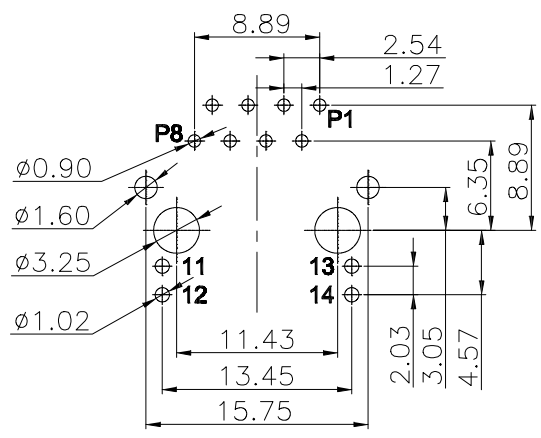

Recommended PCB Layout
(Tolerance:±0.05)

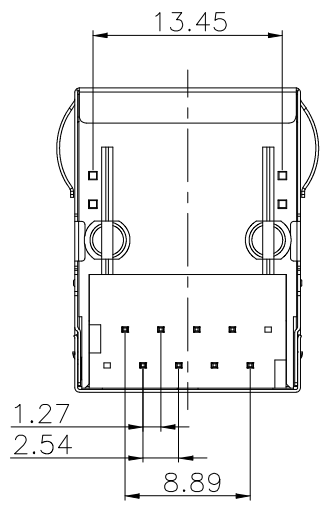
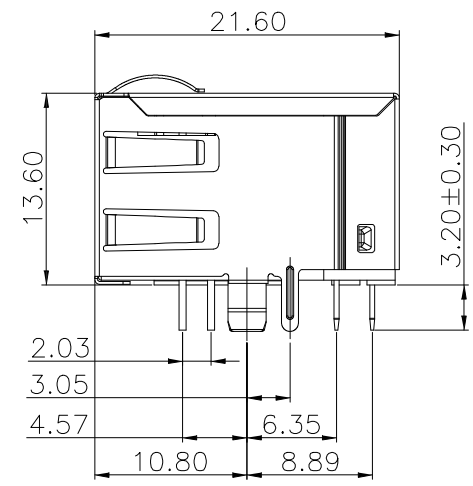
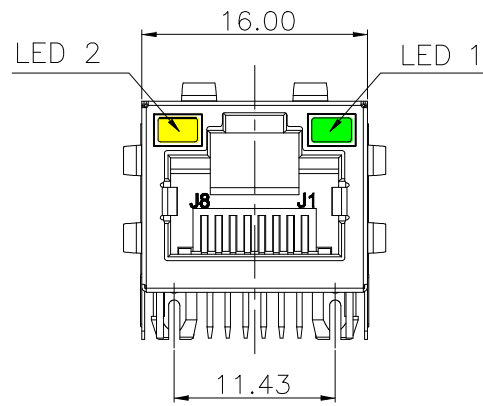
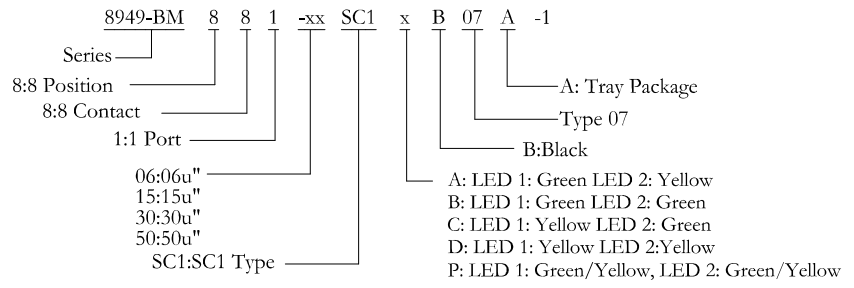

Material:

Housing: PBT, UL94V-0, Black.
 Contacts: Phosphor Bronze, Gold Plated on Contact Area and 100u" Tin Plated on Solder tail over Nickel 50u".
 Metal Shell: Copper Alloy, Nickel Plated 30u"

Electrical Characteristics:

Turn Ratio (+/-2%): 1CT:1CT.
 Inductance OCL: 350uH Min @ 100KHz 0.1V DC BIAS 8mA.
 Insertion Loss: -1.0dB Max @ 1.0~100 MHz.
 Return Loss: -20dB Min @ 1~10 MHz.
 -16dB Min @ 10~30 MHz.
 -12dB Min @ 30~60 MHz.
 -10dB Min @ 60~100 MHz.
 Cross talk: -40dB Min @ 1~30 MHz.
 -35dB Min @ 30~60 MHz.
 -30dB Min @ 60~100 MHz.
 Common Mode Rejection: -35dB Min @ 1~100 MHz.
 -20dB Min @ 50~150 MHz.

Hipot: 1500Vrms/1mA Max.
 Operating Temperature: 40°C~+85°C.

***RoHS Compliant**

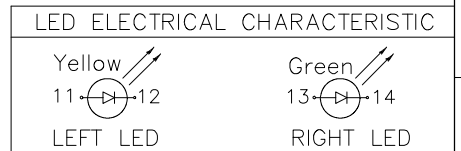



| | | | | | | |
|--------------|------------|-----------------|-------|-----------------------------|----------------|---|
| Tolerances | Dwg. No. | S2820241018-02 | | Title: | 8949-BM Series | |
| .x = ±0.30 | Projection | ⊕ ⊞ | | RJ-45 Modular Jack | | OUPIN ELECTRONIC(KUNSHAN) CO., LTD. P/N: 8949-BM881-xxSC1xB07A-1 |
| .xx = ±0.25 | Unit | mm | Scale | With Transformer 100 Base-T | | |
| .xxx = ±0.10 | Drawn By | Martin 10/18'24 | | ① 676 | | |

| | | | |
|-------|-----|---------|----|
| SHEET | 1/2 | Ver.No. | X1 |
|-------|-----|---------|----|

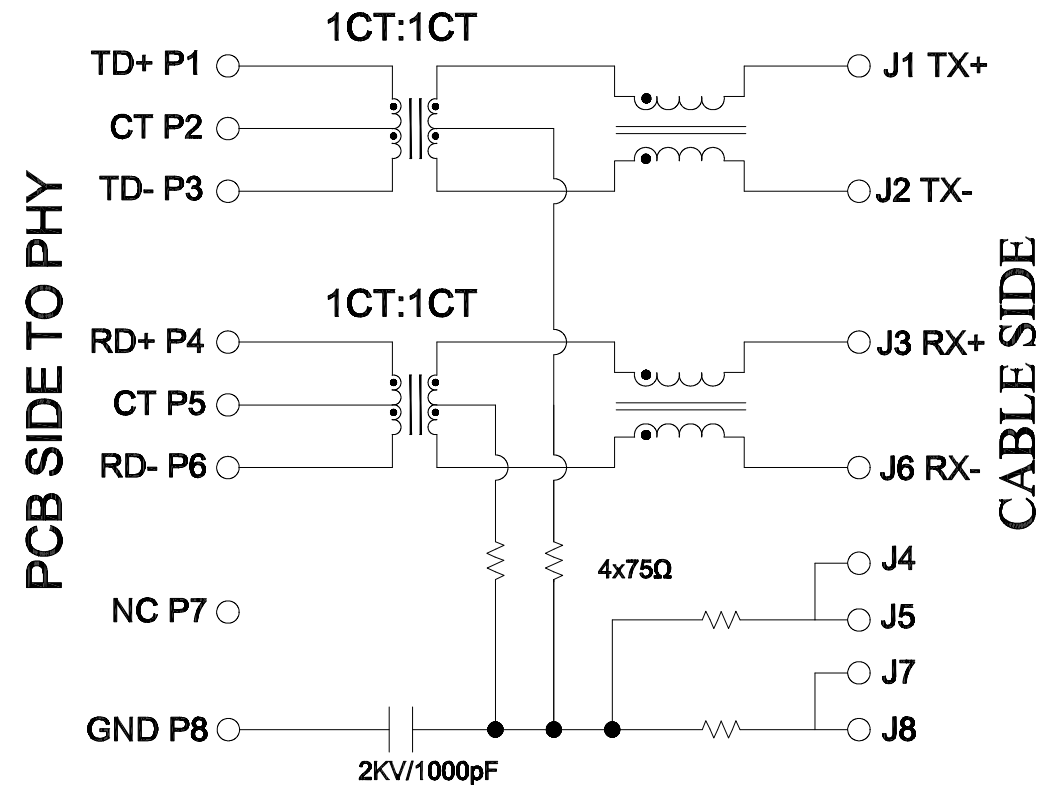
| | | | |
|------|---------------|---------|-------|
| REV. | SPECIFICATION | ECN NO. | APPD. |
| | | | |



Connector Schematic

| | | | | | | |
|---|------------|---|---------|--|---|----------|
| Tolerances .x = ±0.30 .xx = ±0.25 .xxx = ±0.10 | Dwg. No. | S2820241018-02 | | Title: 8949-BM Series RJ-45 Modular Jack With Transformer 100 Base-T ① 676 |  OUPIIN ELECTRONIC(KUNSHAN) CO., LTD. P/N:8949-BM881-xxSC1xB07A-1 | |
| | Projection |  | | | | |
| | Unit | mm | Scale | | | 1:N |
| | Drawn By | Martin | Date | | | 10/18'24 |
| SHEET | | 2/2 | Ver.No. | X1 | | |