

REV.	SPECIFICATION	ECN NO.	APPD.
R8		ECN170312	

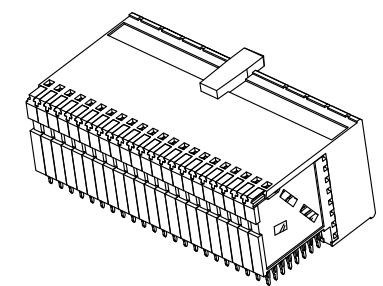

Material:
Housing: Thermoplastic Polyester Glass Filled UL94V-0.
Contacts: Copper Alloy.
Electrical Characteristics:
Current Rating: 1 AMP.
Dielectric Withstanding Voltage: AC 750V For 1 minute.
Insulator Resistance: 10000MΩ min. at DC 500V.
Contact Resistance: 20mΩ max. at DC 100mA.
Operating Temperature: -55°C ~+125°C .
***RoHS Compliant**

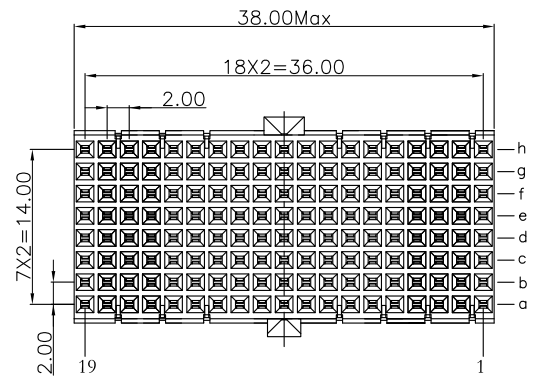
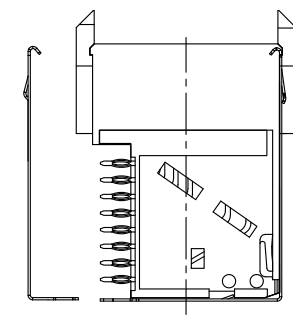
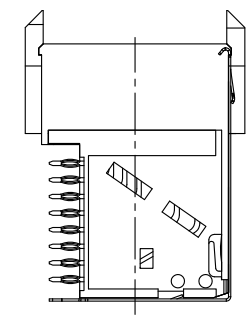
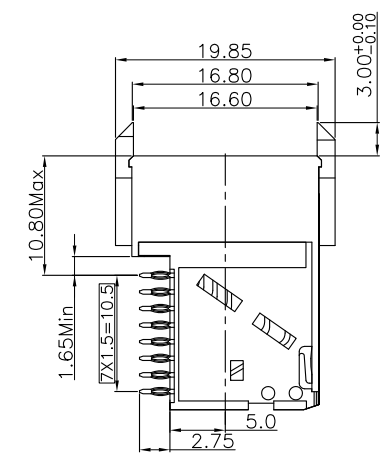
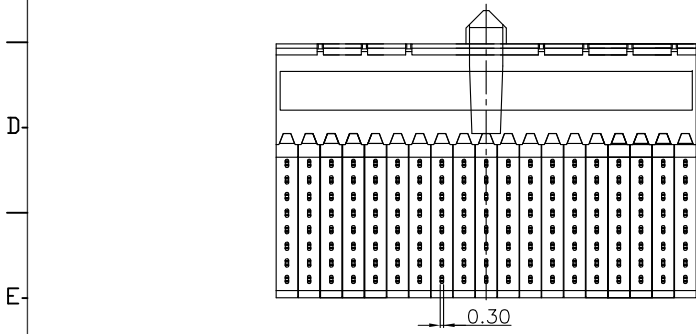

None Shielded

With Top Body Shielded

With Top Body Shielded and Bottom Shielded

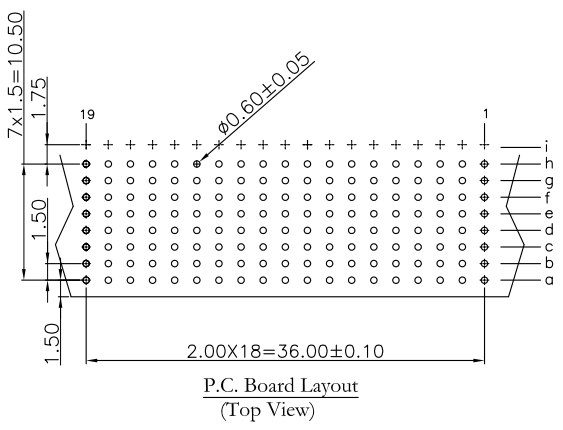

9111- 10 2 DE 152 x CB 30 U
 Series: 10Row, 2: Female, DE: Type DE, Position: 1: None Shielded, 2: Top Body Shielded, 3: Top Body Shielded and Bottom Shielded (Package Separately)
 U: Tube package, 30: 30 u", CB: Dip Tin Plated Contact Au+Pd/Ni Plated

Tolerances	Dwg. No. 9111-D0000-014	Title: 9111 Series Hard Metric Connector Female Right Angle Type DE-19		OUPIN OUPIN ELECTRONIC(KUNSHAN) CO., LTD. P/N:9111-102DE152xCB30U			
x = ±0.5	Projection	Unit mm	Scale 1:1				
.x = ±0.25	Drawn By zbs 03/17'17						
.xx = ±0.15							