

# 歐品電子(昆山)有限公司

OUPIIN ELECTRONIC(KUNSHAN) CO.,LTD.

## PACKAGING SPECIFICATION (包裝作業規範)

CONFIDENTIAL  TOP SECRET

SPEC.NO.(規範編號) Q2243SPP-077		APPLICABLE PRODUCT (適用產品)		2243-xxCxxSPxU 2243-xxCxxSNxU 2243-xxCxxSOxU		PAGE 1/6	REV. K
APPLICABLE CUSTOMER (適用客戶)	一般客戶					PACKAGING CATEGORY (包裝方式)	TUBE PACKING

### REVISION HISTORY (修訂履歷)

REV.	ECN NO	PAGE (頁次)							
		1	2	3	4				
G		Revise the packaging quantity (修改包裝數量.)							
H		ADD P/N 新增料號							
J		ADD P/N 新增料號							
K		Revise the packaging quantity 修改包裝數量							

DIVISION (事業單位)	Product Development (產品開發課)	APPROVED (核准)	CHECKED (審核)	PREPARED (制表)	zbs 04/09'15
-----------------	-----------------------------	---------------	--------------	---------------	--------------

# 歐品電子(昆山)有限公司

OUPIIN ELECTRONIC(KUNSHAN) CO.,LTD.

## PACKAGING SPECIFICATION (包裝作業規範)

SPEC.NO.(規範編號) Q2243SPP-077

<input checked="" type="checkbox"/> CONFIDENTIAL		<input type="checkbox"/> TOP SECRET	
PAGE	2/6	REV.	K

### PACKING OPERATION DIAGRAM & INSTRUCTION (包裝作業圖示及說明)

### REMARK (備注)

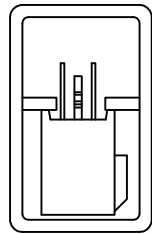

Drawing One: Product Installing Mode  
(圖一產品裝入方式)

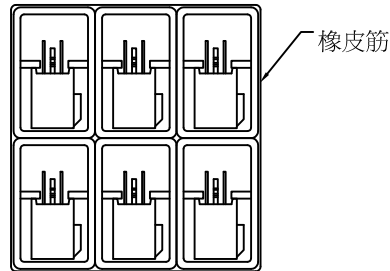

Drawing Two: Six Bundle Eight Tube  
(圖二: 每6管為1捆)

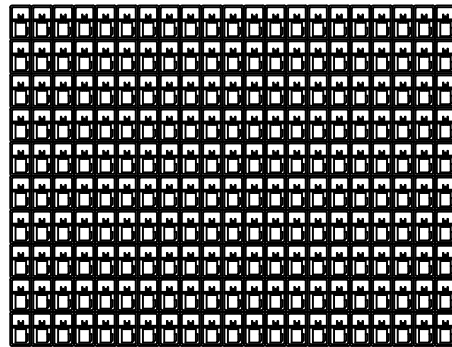

Drawing Three: 7 bundles are put on the eachth floor. Divide 5 layers to put,  
a box amounts to 35 bundles, amounts to 210 tubes  
(圖3)每層放7捆,分5層放入,一盒共35捆,共210管  
Disposing schematic diagram of Tube in the inner box, for reference.  
(管在內盒的擺放示意圖,供參考)

### 一.Inner box packing mode:

#### (內盒包裝方式)

- (1).Each tube packing mode:Stuff one end of tube with stopper, stuff the other end of the tube after load into difinite quality of product. as shown in drawing One.And stuffing in stopper,the end of the stopper must be level with the tube mouth, can't be shown.  
(每管包裝方式:用塞子塞住管子一頭,放入一定數量產品後,塞住另一頭,裝入方式如(圖一)所示.且塞子塞入後,末端要和管口平齊,不可外露.)
- (2).Devide each six tube product in two layers, laying mode:As shown in Drawing Two, the two ends are away from tube mouth 50mm, fix them with 1PCS rubber band.  
(每6管產品分2層,放置方式:如(圖2)所示,兩頭離管口50mm處,各用1PCS橡皮筋纏2道固定.)
- (3).Lay 5 bundles in one case with 5 layers, 7 bundles in one layer , 210 tubes in all. As shown in drawing Three.  
(一盒35捆分5層放入,每層放7捆。共210管。如(圖三)所示)

# 歐品電子(昆山)有限公司

OUPIIN ELECTRONIC(KUNSHAN) CO.,LTD.

PACKAGING SPECIFICATION (包裝作業規範)

<input checked="" type="checkbox"/> CONFIDENTIAL		<input type="checkbox"/> TOP SECRET	
PAGE	3/6	REV.	K

SPEC.NO.(規範編號) Q2243SPP-077

## PACKING OPERATION DIAGRAM & INSTRUCTION (包裝作業圖示及說明)

## REMARK (備注)

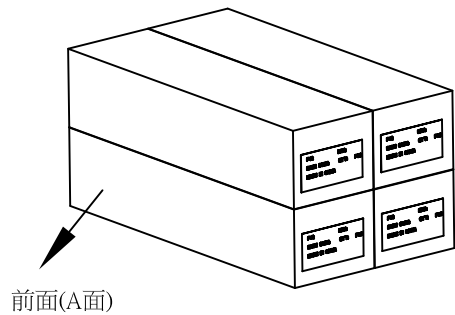

內盒 4PCS  
CT-0  
(規格:460\*130\*105)  
放置方向:A面朝前  
(圖4)

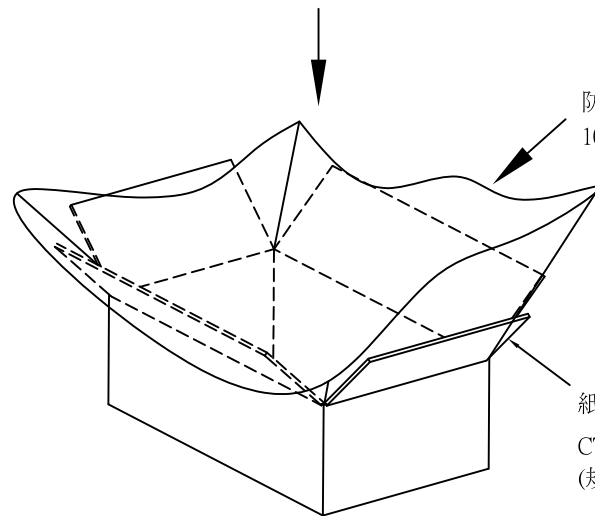

防水袋  
100\*90

紙箱  
CT-0.9  
(規格:475\*275\*225)  
(圖5)

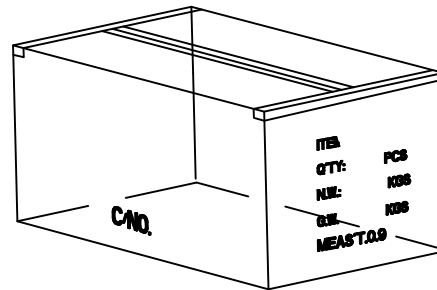

(圖6)

## 二.Outer box packing mode: (外箱包裝方式)

- (1).Paper box CT-0.9 Standart 1 PCS.  
(紙箱CT-0.9規格 1 PCS.)
- (2).Put waterproof bag 1 PCS in the paper box.  
(紙箱內側放入防水袋 1 PCS.)
- (3).Put 4PCS inner box filled with product in the waterproof bag.  
(于防水袋內放入4PCS裝滿產品之內盒.)
- (4).Laying mode of the four inner boxes is that A side in front side.,  
the laying mode of the four inner boxes must in one direction.  
(四個內盒的放置方式為1面朝前放置,四內盒放置方向須一致.)
- (5).The detailed specification of inner box is shown in page two.  
(內盒之詳細包裝規範如第2頁.)
- (6).After laying inner boxes, tie the waterproof bag tightly.Seal the  
surface of the outer box.(Drawing Six)  
(放好內盒,扎緊防水袋。將外箱上層封口。(圖六))

The form on the right and flank side of the bo must be filled correctly  
and clearly, take actual testing weight as the standard of every box  
gross weight.

(外箱之正麥和側麥所要填寫之項目要填寫正確,清晰,每箱之  
毛重應以實測重量為準.)

# 歐品電子(昆山)有限公司

OUPIIN ELECTRONIC(KUNSHAN) CO.,LTD.

## PACKAGING SPECIFICATION (包裝作業規範)

CONFIDENTIAL TOP SECRET

SPEC.NO.(規範編號)		Q2243SPP-077								PAGE:	4/6	REV.	K
PACKING MATERIAL (包裝材料)			PRODUCT P/N	PACKING N.W.	PACKING QUANTITY (包裝數量)					WEIGHT (重量) kg			
MATERIAL NAME (材料名稱)	PART NO. (料號)	Q'TY	(產品料號)	(包材重量)	PCS/TUBE	TUBE/INNER BOX	PCS/INNER BOX	INNER BOX/BOX	PCS/BOX	N.W./PCS	N.W./BOX	G.W./BOX	
PAPER BOXES (紙箱)	CT-0.9	1	2243-10G(C)xxSPxU	12.10	42	210	8820	4	35280	0.000210	7.41	19.51	
PACKING INNER BOX (內紙箱)	CT-0	4	2243-12G(C)xxSPxU	11.21	37	210	7770	4	31080	0.000252	7.83	19.04	
			2243-16G(C)xxSPxU	11.21	30	210	6300	4	25200	0.000336	8.47	19.68	
			2243-20G(C)xxSPxU	11.21	26	210	5460	4	21840	0.000420	9.17	20.38	
TUBE (管子)	TUBE-2242-004	840	2243-22G(C)xxSPxU	11.21	24	210	5040	4	20160	0.000462	9.31	20.52	
			2243-24G(C)xxSPxU	11.21	22	210	4620	4	18480	0.000504	9.31	20.52	
			2243-28G(C)xxSPxU	11.21	19	210	3990	4	15960	0.000588	9.38	20.59	
TUBE PLUG (塞子)	-----	1680	2243-30G(C)xxSPxU	11.21	18	210	3780	4	15120	0.000630	9.53	20.74	
			2243-32G(C)xxSPxU	11.21	17	210	3570	4	14280	0.000672	9.60	20.81	
			2243-34G(C)xxSPxU	11.21	16	210	3360	4	13440	0.000714	9.60	20.81	
WATERPROFF BAG (防水袋)	PE100*70	1	2243-40G(C)xxSPxU	11.21	14	210	2940	4	11760	0.000840	9.88	21.09	
			2243-44G(C)xxSPxU	11.21	13	210	2730	4	10920	0.000924	10.09	21.30	
			2243-50G(C)xxSPxU	11.21	12	210	2520	4	10080	0.001050	10.58	21.79	
DRYING AGENT (干燥劑)	-----	3	2243-60G(C)xxSPxU	11.21	10	210	2100	4	8400	0.001260	10.58	21.79	
			2243-70G(C)xxSPxU	11.21	8	210	1680	4	6720	0.001470	9.88	21.09	
RUBBER RIBE (橡皮筋)	-----	280	2243-72G(C)xxSPxU	11.21	8	210	1680	4	6720	0.001512	10.16	21.37	
			2243-80G(C)xxSPxU	11.21	7	210	1470	4	5880	0.001680	9.88	21.09	
			2243-100G(C)xxSPxU	11.21	6	210	1260	4	5040	0.002100	10.58	21.79	

1.NOTE:  
 (注意) When the finished products have been made,take the actual weight as the standard of gross weight in each box.  
 (成品出貨時,每箱之毛重應以實測重量為準)  
 When the finished products have been made,stick the proper designation list on the box according to product demand.  
 (成品出貨時,依據出貨要求貼上相對應的標籤單)  
 CT-1.6 Produce goods taiwan ,CT-1.9 Produce goods shanghai. (CT-1.6出貨台灣OP • CT-1.9出貨上海SH)  
 It doesn't influence the manner of packing with the gold-plated way to print word way.Can amalgamate.(印字方式跟鍍金方式不影響包裝方式,可以共用)

# 歐品電子(昆山)有限公司

OUPIIN ELECTRONIC(KUNSHAN) CO.,LTD.

## PACKAGING SPECIFICATION (包裝作業規範)

CONFIDENTIAL TOP SECRET

SPEC.NO.(規範編號)		Q2243SPP-077								PAGE:	5/6	REV.	K
PACKING MATERIAL (包裝材料)			PRODUCT P/N	PACKING N.W.	PACKING QUANTITY (包裝數量)					WEIGHT (重量) kg			
MATERIAL NAME (材料名稱)	PART NO. (料號)	Q'TY	(產品料號)	(包材重量)	PCS/TUBE	TUBE/INNER BOX	PCS/INNER BOX	INNER BOX/BOX	PCS/BOX	N.W./PCS	N.W./BOX	G.W./BOX	
PAPER BOXES (紙箱)	CT-0.9	1	2243-10G(C)xxSNxU	12.10	63	210	13230	4	52920	0.000183	9.70	21.80	
PACKING INNER BOX (內紙箱)	CT-0	4	2243-12G(C)xxSNxU	11.21	53	210	11130	4	44520	0.000220	9.79	21.00	
			2243-16G(C)xxSNxU	11.21	40	210	8400	4	33600	0.000293	9.86	21.07	
			2243-20G(C)xxSNxU	11.21	32	210	6720	4	26880	0.000367	9.86	21.07	
TUBE (管子)	TUBE-2242-004	840	2243-22G(C)xxSNxU	11.21	29	210	6090	4	24360	0.000403	9.83	21.04	
			2243-24G(C)xxSNxU	11.21	27	210	5670	4	22680	0.000440	9.98	21.19	
			2243-28G(C)xxSNxU	11.21	23	210	4830	4	19320	0.000513	9.92	21.13	
TUBE PLUG (塞子)	-----	1680	2243-30G(C)xxSNxU	11.21	22	210	4620	4	18480	0.000550	10.16	21.37	
			2243-32G(C)xxSNxU	11.21	20	210	4200	4	16800	0.000587	9.86	21.07	
			2243-34G(C)xxSNxU	11.21	19	210	3990	4	15960	0.000623	9.95	21.16	
WATERPROFF BAG (防水袋)	PE100*70	1	2243-40G(C)xxSNxU	11.21	16	210	3360	4	13440	0.000733	9.86	21.07	
			2243-44G(C)xxSNxU	11.21	15	210	3150	4	12600	0.000807	10.16	21.37	
			2243-50G(C)xxSNxU	11.21	13	210	2730	4	10920	0.000917	10.01	21.22	
DRYING AGENT (干燥劑)	-----	3	2243-60G(C)xxSNxU	11.21	11	210	2310	4	9240	0.001100	10.16	21.37	
			2243-70G(C)xxSNxU	11.21	9	210	1890	4	7560	0.001283	9.70	20.91	
RUBBER RIBE (橡皮筋)	-----	280	2243-72G(C)xxSNxU	11.21	9	210	1890	4	7560	0.001320	9.98	21.19	
			2243-80G(C)xxSNxU	11.21	8	210	1680	4	6720	0.001467	9.86	21.07	
			2243-100G(C)xxSNxU	11.21	6	210	1260	4	5040	0.001833	9.24	20.45	

1.NOTE:  
 (注意) When the finished products have been made,take the actual weight as the standard of gross weight in each box.  
 (成品出貨時,每箱之毛重應以實測重量為準)  
 When the finished products have been made,stick the proper designation list on the box according to product demand.  
 (成品出貨時,依據出貨要求貼上相對應的標籤單)  
 CT-1.6 Produce goods taiwan ,CT-1.9 Produce goods shanghai. (CT-1.6出貨台灣OP • CT-1.9出貨上海SH)  
 It doesn't influence the manner of packing with the gold-plated way to print word way.Can amalgamate.(印字方式跟鍍金方式不影響包裝方式,可以共用)

# 歐品電子(昆山)有限公司

OUPIIN ELECTRONIC(KUNSHAN) CO.,LTD.

## PACKAGING SPECIFICATION (包裝作業規範)

CONFIDENTIAL TOP SECRET

SPEC.NO.(規範編號)		Q2243SPP-077								PAGE:	6/6	REV.	K
PACKING MATERIAL (包裝材料)			PRODUCT P/N	PACKING N.W.	PACKING QUANTITY (包裝數量)					WEIGHT (重量) kg			
MATERIAL NAME (材料名稱)	PART NO. (料號)	Q'TY	(產品料號)	(包材重量)	PCS/TUBE	TUBE/INNER BOX	PCS/INNER BOX	INNER BOX/BOX	PCS/BOX	N.W./PCS	N.W./BOX	G.W./BOX	
PAPER BOXES (紙箱)	CT-0.9	1	2243-10G(C)xxSOxU	11.21	42	210	8820	4	35280	0.000210	7.41	18.62	
PACKING INNER BOX (內紙箱)	CT-0	4	2243-12G(C)xxSOxU	11.21	37	210	7770	4	31080	0.000252	7.83	19.04	
			2243-16G(C)xxSOxU	11.21	30	210	6300	4	25200	0.000336	8.47	19.68	
			2243-20G(C)xxSOxU	11.21	26	210	5460	4	21840	0.000420	9.17	20.38	
TUBE (管子)	TUBE-2242-004	840	2243-22G(C)xxSOxU	11.21	24	210	5040	4	20160	0.000462	9.31	20.52	
			2243-24G(C)xxSOxU	11.21	22	210	4620	4	18480	0.000504	9.31	20.52	
			2243-28G(C)xxSOxU	11.21	19	210	3990	4	15960	0.000588	9.38	20.59	
TUBE PLUG (塞子)	-----	1680	2243-30G(C)xxSOxU	11.21	18	210	3780	4	15120	0.000630	9.53	20.74	
			2243-32G(C)xxSOxU	11.21	17	210	3570	4	14280	0.000672	9.60	20.81	
			2243-34G(C)xxSOxU	11.21	16	210	3360	4	13440	0.000714	9.60	20.81	
WATERPROFF BAG (防水袋)	PE100*70	1	2243-40G(C)xxSOxU	11.21	14	210	2940	4	11760	0.000840	9.88	21.09	
			2243-44G(C)xxSOxU	11.21	13	210	2730	4	10920	0.000924	10.09	21.30	
			2243-50G(C)xxSOxU	11.21	12	210	2520	4	10080	0.001050	10.58	21.79	
DRYING AGENT (干燥劑)	-----	3	2243-60G(C)xxSOxU	11.21	10	210	2100	4	8400	0.001260	10.58	21.79	
			2243-70G(C)xxSOxU	11.21	8	210	1680	4	6720	0.001470	9.88	21.09	
RUBBER RIBE (橡皮筋)	-----	280	2243-72G(C)xxSOxU	11.21	8	210	1680	4	6720	0.001512	10.16	21.37	
			2243-80G(C)xxSOxU	11.21	7	210	1470	4	5880	0.001680	9.88	21.09	
			2243-100G(C)xxSOxU	11.21	6	210	1260	4	5040	0.002100	10.58	21.79	

1.NOTE:  
 (注意) When the finished products have been made,take the actual weight as the standard of gross weight in each box.  
 (成品出貨時,每箱之毛重應以實測重量為準)  
 When the finished products have been made,stick the proper designation list on the box according to product demand.  
 (成品出貨時,依據出貨要求貼上相對應的標籤單)  
 CT-1.6 Produce goods taiwan ,CT-1.9 Produce goods shanghai. (CT-1.6出貨台灣OP • CT-1.9出貨上海SH)  
 It doesn't influence the manner of packing with the gold-plated way to print word way.Can amalgamate.(印字方式跟鍍金方式不影響包裝方式,可以共用)