

# 歐品電子(昆山)有限公司

OUPIN ELECTRONIC(KUNSHAN) CO.,LTD.

PACKAGING SPECIFICATION (包裝作業規範)

CONFIDENTIAL  TOP SECRET

SPEC.NO.(規範編號)	Q2243SPP-123	APPLICABLE CUSTOMER (適用客戶)	ALL	APPLICABLE PRODUCT (適用產品)	2243-xxG(C)xxDxT-x	PAGE	1/6	REV.	Y	PACKAGING CATEGORY (包裝方式)	TAPE REEL
----------------	--------------	----------------------------	-----	---------------------------	--------------------	------	-----	------	---	---------------------------	-----------

## REVISE HISTORY (修訂履歷)

REV.	ECN NO.	頁次 PAGE							
		1	2	3	4				
R		Add P/N (新增料號.)							
S		Modify the packing instruction (修改包裝說明.)							
T		Add P/N (新增料號.)							
U		Add P/N (新增料號.)							
V		Modify the packing instruction (修改包裝說明.)							
w		Modify the image (修改圖片)							
Y		Updated packing specification (更新包裝規範)							

DIVISION (事業單位)	Product Develop (產品開發課)	APPROVED (核准)	CHECKED (審核)	PREPARED (制表)	P E: D E:	CCH '08/16'23
-----------------	-------------------------	---------------	--------------	---------------	--------------	---------------

# 歐品電子(昆山)有限公司

OUPIIN ELECTRONIC(KUNSHAN) CO.,LTD.

PACKAGING SPECIFICATION (包裝作業規範)

CONFIDENTIAL  TOP SECRET

SPEC.NO.(規範編號) Q2243SPP-123

PAGE 2/6 REV. Y

## PACKING OPERATION DIAGRAM & INSTRUCTION (包裝作業圖示及說明)

## REMARK (備注)

### Heat plastic-band packing manner 封帶包裝方式

The road hole must be laid at the right of the drawing direction.  
(導向圓孔必須設在拉延方向的右側)

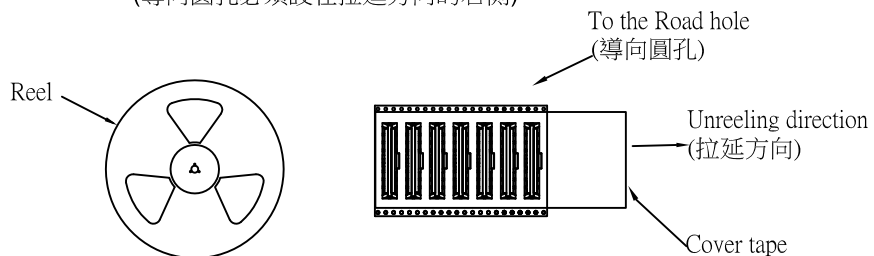

The beginning of the band, the detailed chart of the end.  
(封帶開始部分, 結束部分的詳細圖)

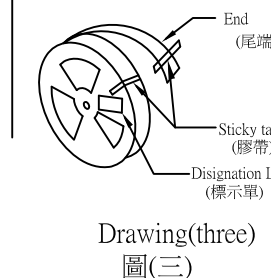
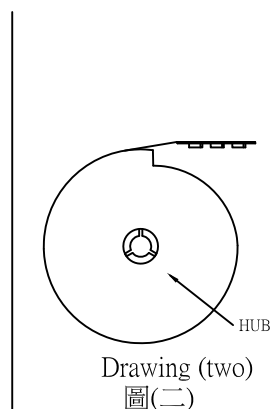
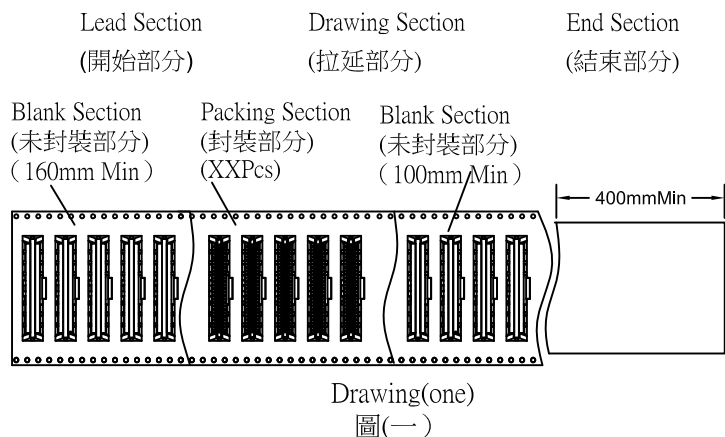

產品金屬或塑膠PAD有防呆時PAD需与包材缺口匹配,包材圓孔在上。

### 一.Packing of interior box: (內盒包裝方式)

- (1)Packaging way of each reel is shown in drawing one.  
(每個REEL包裝方式,如圖(一)所示)
- (2) At the beginning of winding belt,take one part of sticky belt with 60 mm length,15mm width. stick 20 mm on the material belt,stick 40 mm on the gap of the REEL mandrel , as shown in drawing two.  
(在開始纏繞料帶時,取長60mm寬15mm之膠帶一段,20mm 黏于料帶上,40mm 黏于REEL心軸之缺口上,如圖(二)所示)
- (3) Use one REEL can package xx PCS products .  
(每卷REEL可包裝 xx PCS產品)
- (4)After winding the material belt, stick the COVER TAPE with 60 mmlength, 15 mm width stick belt, and fix it on the circumference of the REEL, as shown in drawing three.  
(料帶卷繞完成時取長60mm寬15mm之3M膠帶黏住COVER TAPE并將其固定在REEL之圓周上,如圖(三)所示)
- (5). plastic convex sets and packaging material gap should be in the same direction,tilt,such as product in the packaging material should be took that into the direction of the product.  
塑膠凸台與包材缺口需在同一方向,如產品放入包材後有傾斜,需將產品拿出重新確認放入的方向。

\*. Stick sticky belt(18mm width,40 length) on the two sides when COVER TAPE is interrupted, stick each end with20 mm belt to get them together.and the two COVER TAPE connected must be at the same line.  
(COVER TAPE 有中斷時可用寬18mm,長40mm之膠帶將中斷之兩端各貼20mm,使其連接為一體.但連接后的兩段COVER TAPE應在同一直線上.)

# 歐品電子(昆山)有限公司

OUPIIN ELECTRONIC(KUNSHAN) CO.,LTD.

PACKAGING SPECIFICATION (包裝作業規範)

CONFIDENTIAL TOP SECRET

PAGE 3/6 REV. Y

SPEC.NO.(規範編號) Q2243SPP-123

## PACKING OPERATION DIAGRAM & INSTRUCTION (包裝作業圖示及說明)

## REMARK (備注)

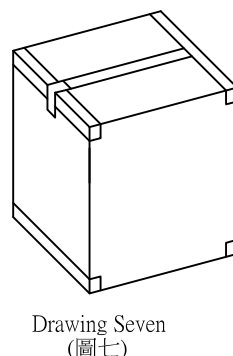
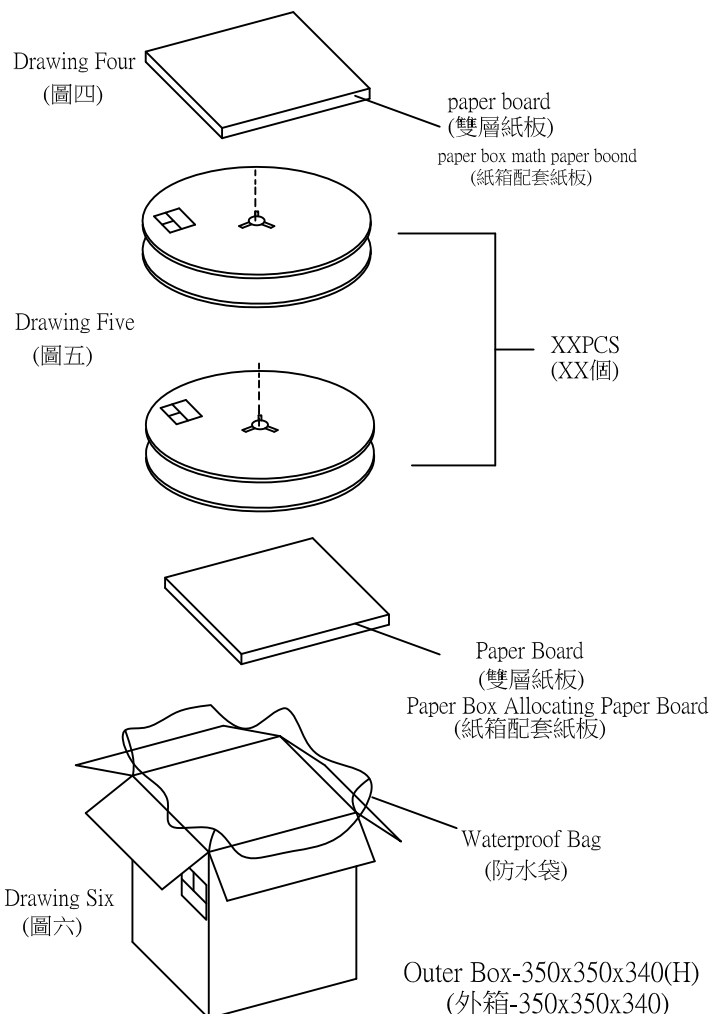

### 2. Outer box packing mode: (二.外箱包裝方式)

- (1) Paper box (CT-1.5) 1PCS (Drawing Six). (紙箱CT-1.5 1PCS 圖六).
- (2) Put 1 pcs allocating paper board at the bottom of the box, then put 1 PCS waterproof bag on the board (Drawing Six). (底層放入紙箱配套紙板 1PCS. 上面放入防水袋 1PCS (圖六)).
- (3) After folding XX pieces of reel disk, seal the waterproof bag (Drawing Five). (疊好 XX 個 Reel 盤後封上防水袋 圖五).
- (4) Put 1 PCS double decked paper board on the top of box (Drawing Four). (最上層放入雙層紙板 1PCS 圖四).
- (5) Seal the surface of the outer box (Drawing Seven). (將外箱上層封口 圖七).

\*The form on the right and flank side of the box must be filled correctly and clearly, take actual testing weight as the standard of every box gross weight.

(\*外箱之正面和側面所要填寫之項目要填寫正確, 清晰, 每箱之毛重應以實測重量為準.)

**歐品電子(昆山)有限公司**  
**OUPIN ELECTRONIC(KUNSHAN) CO.,LTD.**  
**PACKAGING SPECIFICATION (包裝作業規範)**

CONFIDENTIAL     TOP SECRET  
 PAGE:    4/6    REV.    Y

SPEC.NO.(規範編號)    Q2243SPP-123

PACKING MATERIAL (包裝材料)			PRODUCT P/N	TAPE REEL STANDARD	PACKING P/N	PACKING N.W.	PACKING QUANTITY (包裝數量)			WEIGHT (重量) kg		
MATERIAL NAME (材料名稱)	PART NO. (料號)	QTY	(產品料號)	(包材規格mm)	(包材料號)	(包材重量)	PCS/REEL	REEL/BOX	PCS/BOX	N.W./PCS	N.W./BOX	G.W./BOX
PAPER BOXES (紙箱)	CT-1.5	1	2243-10xxxDxT-P	24	2243-K1024-001	5.31	800	11	8800	0.00018	1.58	6.89
WATERPROOF BAG (防水袋)	100x70	1			COVER-K0024-001							
					REEL-K0024-001							
DOUBLE DECKED PAPER BOARD (雙層紙板)	340x340x5	2	2243-18Cxx-DPT-P	32	2243-K1832-001	3.72	800	8	6400	0.00073	4.67	8.39
					COVER-K0032-001							
3M FIBER BELT (3M纖維膠帶)	-----	-----	2243-20CxxDxT-M	32	2243-K2032-001	3.72	800	8	6400	0.00073	4.67	8.39
					COVER-K0032-001							
			2243-28xxxDxT-P	44	2243-K2844-001	3.91	800	6	4800	0.000504	2.42	6.33
					COVER-K0044-001							
					REEL-K0044-001							
			2243-30xxxDxT-P	44	2243-K3044-001	3.91	800	6	4800	0.00054	2.59	6.50
					COVER-K0044-001							
					REEL-K0044-001							
			2243-32xxxDxT-P	44	2243-K3244-001	3.97	800	6	4800	0.000576	2.76	6.73
					COVER-K0044-001							
					REEL-K0044-001							

1.NOTE:  
(注意)  
When the finished products have been made,take the actual weight as the standard of gross weight in each box.  
(成品出貨時,每箱之毛重應以實測重量為準)  
When the finished products have been made,stick the proper designation list on the box according to product de

2.NOTE:  
(注意)  
\*Pay attention to each big reel of material ,can be divided into 3 small reels,consumption of each big reel can't exceed 1meter, or the third reel can't be packed  
(來料每大卷reel (carrier tape) 平均可分3小卷reel , 每大卷reel 消耗量不可超過1米,否則第三小卷不可包裝.)

**歐品電子(昆山)有限公司**  
**OUPIN ELECTRONIC(KUNSHAN) CO.,LTD.**  
**PACKAGING SPECIFICATION (包裝作業規範)**

CONFIDENTIAL     TOP SECRET

SPEC.NO.(規範編號)		Q2243SPP-123				PAGE:		5/6		REV.		Y	
PACKING MATERIAL (包裝材料)			PRODUCT P/N	TAPE REEL STANDARD	PACKING P/N	PACKING N.W.	PACKING QUANTITY (包裝數量)			WEIGHT (重量) kg			
MATERIAL NAME (材料名稱)	PART NO. (料號)	Q'TY	(產品料號)	(包材規格mm)	(包材料號)	(包材重量)	PCS/REEL	REEL/BOX	PCS/BOX	N.W./PCS	N.W./BOX	G.W./BOX	
PAPER BOXES (紙箱)	CT-1.5	1	2243-40xxxDxT-M(S)	44	2243-K4044-001	3.91	800	6	4800	0.00072	3.46	7.37	
WATERPROOF BAG (防水袋)	100x70	1			COVER-K0044-001								
DOUBLE DECKED PAPER BOARD (雙層紙板)	340x340x5	2	2243-44xxxDxT-P	44	2243-K4444-001	3.91	800	6	4800	0.000792	3.80	7.71	
					COVER-K0044-001								
3M FIBER BELT (3M纖維膠帶)	-----	-----	2243-50xxxDxT-M	56	2243-K5056-001	3.72	800	5	4000	0.0009	3.60	7.32	
					COVER-K0056-001								
			2243-56xxxDxT-P	56	2243-K5656-001	3.72	800	5	4000	0.00108	4.32	8.04	
					COVER-K0056-001								
			2243-60xxxDxT-P	56	2243-K6056-004	3.72	800	5	4000	0.00108	4.32	8.04	
					COVER-K0056-001								
			2243-64xxxDxT-P	56	2243-K6472-001	3.10	800	5	4000	0.00144	5.76	8.86	
					COVER-K0056-001								

1.NOTE:  
 (注意)  
 When the finished products have been made,take the actual weight as the standard of gross weight in each box.  
 (成品出貨時,每箱之毛重應以實測重量為準)  
 When the finished products have been made,stick the proper designation list on the box according to product demand.  
 (成品出貨時,依據出貨要求貼上相對應的標籤單)

2.NOTE:  
 (注意)  
 \*Pay attention to each big reel of material ,can be divided into 3 small reels,consumption of each big reel can't exceed 1meter, or the third reel can't be packed  
 (來料每大卷reel (carrier tape) 平均可分3小卷reel , 每大卷reel 消耗量不可超過1米,否則第三小卷不可包裝.)

**歐品電子(昆山)有限公司**  
**OUPIN ELECTRONIC(KUNSHAN) CO.,LTD.**  
**PACKAGING SPECIFICATION (包裝作業規範)**

CONFIDENTIAL     TOP SECRET  
 PAGE:    6/6    REV.    Y

SPEC.NO.(規範編號)			Q2243SPP-123									
PACKING MATERIAL (包裝材料)			PRODUCT P/N	TAPE REEL STANDARD	PACKING P/N	PACKING N.W.	PACKING QUANTITY (包裝數量)			WEIGHT (重量) kg		
MATERIAL NAME (材料名稱)	PART NO. (料號)	Q'TY	(產品料號)	(包材規格mm)	(包材料號)	(包材重量)	PCS/REEL	REEL/BOX	PCS/BOX	N.W./PCS	N.W./BOX	G.W./BOX
PAPER BOXES (紙箱)	CT-1.5	1	2243-80xxxDxT-P(M)	72	2243-K8072-001	3.10	800	4	3200	0.00144	4.61	7.71
WATERPROOF BAG (防水袋)	100x70	1			COVER-K0072-001							
					REEL-K0072-001							
DOUBLE DECKED PAPER BOARD (雙層紙板)	340x340x5	2	2243-100xxxDxT-P	88	2243-K10088-001	3.21	800	3	2400	0.0018	4.32	7.53
					COVER-K0088-001							
3M FIBER BELT (3M纖維膠帶)	-----	-----	2243-16xxxDxT-P	24	2243-K1624-001	5.31	800	11	8800	0.00018	1.58	6.89
					COVER-K0024-001							

<p>1.NOTE: (注意) When the finished products have been made,take the actual weight as the standard of gross weight in each box. (成品出貨時,每箱之毛重應以實測重量為準) When the finished products have been made,stick the proper designation list on the box according to product demand. (成品出貨時,依據出貨要求貼上相對應的標籤單)</p>	<p>2.NOTE: (注意) *Pay attention to each big reel of material ,can be divided into 3 small reels,consumption of each big reel can't exceed 1meter, or the third reel can't be packed (來料每大卷reel (carrier tape) 平均可分3小卷reel , 每大卷reel 消耗量不可超過1米,否則第三小卷不可包裝.)</p>
---	---