

歐品電子(昆山)有限公司

OUPIIN ELECTRONIC(KUNSHAN) CO.,LTD.

PACKAGING SPECIFICATION (包裝作業規範)

CONFIDENTIAL TOP SECRET

SPEC.NO.(規範編號) Q2041SPP-348		APPLICABLE PRODUCT (適用產品) 2041-1XxxGxxRA		PAGE 1/6	REV. E
APPLICABLE CUSTOMER (適用客戶) ALL				PACKAGING CATEGORY (包裝方式) TRAY PLATE PACKING	

REVISION HISTORY (修訂履歷)

ECN REV. NO	PAGE (頁次)								
	1	2	3	4	5	6			
D	Amend packing load (修改包裝數量.)								
E	Amend packing load (修改包裝數量.)								

DIVISION (事業單位) Product Development (產品開發課)	APPROVED (核准)	CHECKED (審核)	PREPARED (制表) NWJ 03/28'16
---	---------------	--------------	----------------------------

歐品電子(昆山)有限公司

OUPIIN ELECTRONIC(KUNSHAN) CO.,LTD.

PACKAGING SPECIFICATION (包裝作業規範)

CONFIDENTIAL TOP SECRET

SPEC.NO.(規範編號) Q2041SPP-348

PAGE 2/6 REV. E

PACKING OPERATION DIAGRAM & INSTRUCTION (包裝作業圖示及說明)

REMARK (備注)

Laying Product Diagram:

(產品擺放圖示)

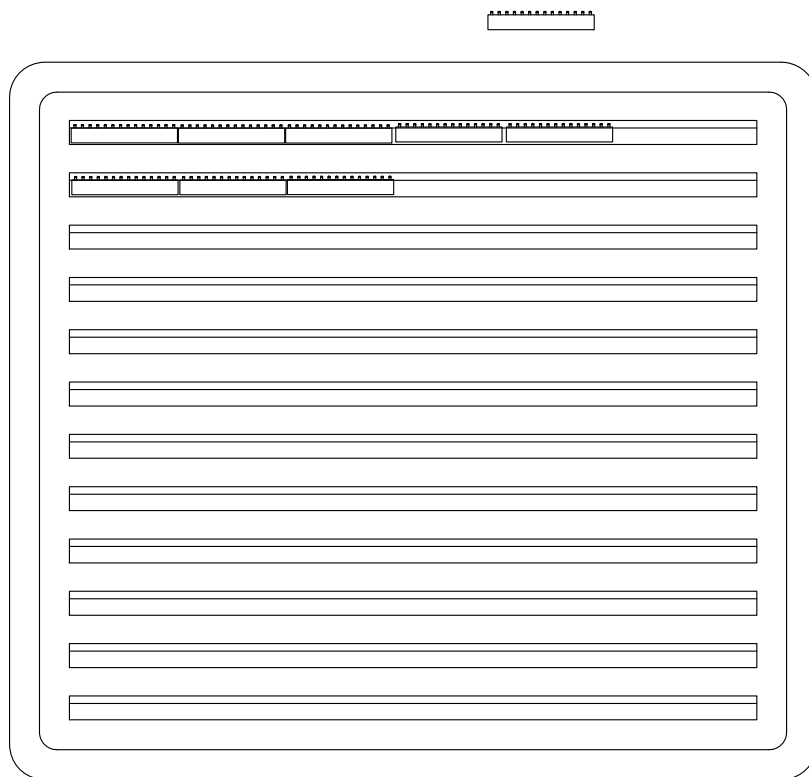

一.PVC Plate Packing Mode:

(PVC盤包裝方式)

(1).CT-1.6 Box: PVC-2041-01 xxPCS.

(CT-1.6 規格的紙箱放PVC-2041-01盤 xx PCS)

(2).Put product in each trough fully as shown in diagram.

(產品在盤子中擺放方式如圖所示)

(3).After filling each trough with product fully,cover it with transparent upper cover PVC-2041-02 1PCS。

(每盤放滿產品後,加蓋透明上蓋 PVC-2041-02 1PCS)

(4).Stack the XX PVC plates filled with product, put them in the paper box in which has been put waterproof bag.

(將放滿產品的 XX 個PVC盤疊起,裝入防水袋放入紙箱內)

歐品電子(昆山)有限公司

OUPIIN ELECTRONIC(KUNSHAN) CO.,LTD.

PACKAGING SPECIFICATION (包裝作業規範)

<input checked="" type="checkbox"/> CONFIDENTIAL		<input type="checkbox"/> TOP SECRET	
PAGE	3/6	REV.	E

SPEC.NO.(規範編號) Q2041SPP-348

PACKING OPERATION DIAGRAM & INSTRUCTION (包裝作業圖示及說明)	REMARK (備注)
---	-------------

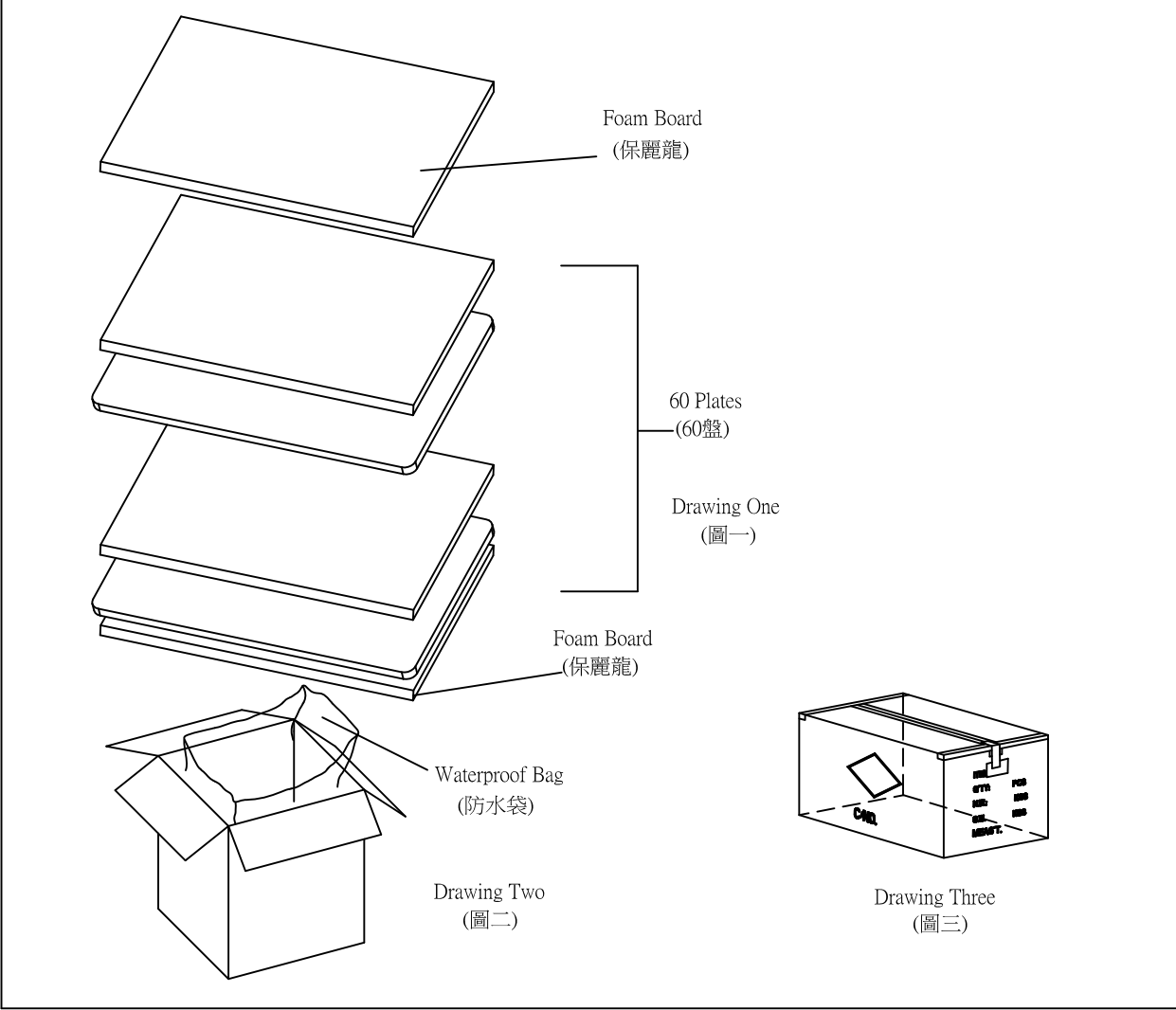

一.Outer Box Packing Mode:
(外箱包裝方式)

- (1).Paper box 1.6or 1.6 standard 1 PCS,as shown in drawing Two.
(1.6規格 1 PCS.如(圖二)所示)
- (2).Put one Foam Board in the upper and lower of the paper box,,2PCS in all.,as shown in drawing One.
(每箱上下各放一塊保麗龍,共2PCS,如(圖一)所示)
- (3).Put 1 PCS waterproof in the paper box,as shown in drawing Two.
(紙箱內側放入防水袋 1 PCS.如(圖二)所示)
- (4).Piled the XX packing plates packed up in the waterproof.
(將放滿產品的22/17個PVC盤疊起,裝入防水袋內)
- (5).Seal the waterproof bag,then put the Foam Board 1PCS on the bag.
(Put 1 PCS Foam Board at the right and left side in the paper box if it is necessary.)
(封上防水袋,然後放上第二塊保麗龍薄板)
(必要時,在紙箱的左右兩側各放一塊保麗龍)
- (6).Seal the surface of the outer box,as shown in drawing Three.
(將外箱上層封口.如(圖三)所示)

The form on the right and flank side of the box must be filled correctly and clearly,take actual testing weight as the standard of each box gross weight.
外箱之正麥和側麥所要填寫之項目要填寫正確,清晰,每箱之毛重應以實測重量為準.

歐品電子(昆山)有限公司

OUIPIN ELECTRONIC(KUNSHAN) CO.,LTD.

PACKAGING SPECIFICATION (包裝作業規範)

<input checked="" type="checkbox"/> CONFIDENTIAL <input type="checkbox"/> TOP SECRET	
PAGE:	4/6 REV. E

SPEC.NO.(規範編號)	Q2041SPP-348																							
<table border="1" style="width: 100%; border-collapse: collapse;"> <tr> <th style="width: 30%;">PACKING MATERIAL (包裝材料)</th> <th style="width: 10%;">PRODUCT P/N</th> <th style="width: 10%;">CT NO.</th> <th style="width: 10%;">PACKING N.W.</th> <th colspan="3" style="width: 30%;">PACKING QUANTITY (包裝數量)</th> <th colspan="3" style="width: 20%;">WEIGHT (重量) kg</th> </tr> <tr> <th>MATERIAL NAME (材料名稱)</th> <th>PART NO. (料號)</th> <th>Q'TY</th> <th>(產品料號)</th> <th>(紙箱規格)</th> <th>(包材重量)</th> <th>PCS/TRAY</th> <th>TRAY/BOX</th> <th>PCS/BOX</th> <th>N.W./PCS</th> <th>N.W./BOX</th> <th>G.W./BOX</th> </tr> </table>			PACKING MATERIAL (包裝材料)	PRODUCT P/N	CT NO.	PACKING N.W.	PACKING QUANTITY (包裝數量)			WEIGHT (重量) kg			MATERIAL NAME (材料名稱)	PART NO. (料號)	Q'TY	(產品料號)	(紙箱規格)	(包材重量)	PCS/TRAY	TRAY/BOX	PCS/BOX	N.W./PCS	N.W./BOX	G.W./BOX
PACKING MATERIAL (包裝材料)	PRODUCT P/N	CT NO.	PACKING N.W.	PACKING QUANTITY (包裝數量)			WEIGHT (重量) kg																	
MATERIAL NAME (材料名稱)	PART NO. (料號)	Q'TY	(產品料號)	(紙箱規格)	(包材重量)	PCS/TRAY	TRAY/BOX	PCS/BOX	N.W./PCS	N.W./BOX	G.W./BOX													
PAPER BOXES (紙箱)	CT-0.9	1	2041-1X2GxxRA	CT-0.9	0.60	468	60	28080	0.000155	4.35	4.95													
Packing Box (包裝盒)	PVC-2041-01	---	2041-1X3GxxRA	CT-0.9	0.60	312	60	18720	0.0002325	4.35	4.95													
			2041-1X4GxxRA	CT-0.9	0.60	228	60	13680	0.00031	4.24	4.84													
			2041-1X5GxxRA	CT-0.9	0.60	180	60	10800	0.0003875	4.19	4.79													
Packing Box Cover (包裝盒蓋子)	PVC-2041-02	---	2041-1X6GxxRA	CT-0.9	0.60	156	60	9360	0.000465	4.35	4.95													
			2041-1X7GxxRA	CT-0.9	0.60	132	60	7920	0.0005425	4.30	4.90													
			2041-1X8GxxRA	CT-0.9	0.60	108	60	6480	0.00062	4.02	4.62													
WATERPROOF BAG (防水袋)	PE 100*90	1	2041-1X9GxxRA	CT-0.9	0.60	96	60	5760	0.0006975	4.02	4.62													
			2041-1X10GxxRA	CT-0.9	0.60	96	60	5760	0.000775	4.46	5.06													
			2041-1X11GxxRA	CT-0.9	0.60	84	60	5040	0.0008525	4.30	4.90													
Foam (保麗龍)	-----	2	2041-1X12GxxRA	CT-0.9	0.60	72	60	4320	0.00093	4.02	4.62													
			2041-1X13GxxRA	CT-0.9	0.60	72	60	4320	0.0010075	4.35	4.95													
			2041-1X14GxxRA	CT-0.9	0.60	60	60	3600	0.001085	3.91	4.51													
DRYING AGENT (干燥劑)	-----	3	2041-1X15GxxRA	CT-0.9	0.60	60	60	3600	0.0011625	4.19	4.79													
			2041-1X16GxxRA	CT-0.9	0.60	48	60	2880	0.00124	3.57	4.17													
			2041-1X17GxxRA	CT-0.9	0.60	48	60	2880	0.0013175	3.79	4.39													

1.NOTE:
 (注意) When the finished products have been made,take the actual weight as the standard of gross weight in each box.
 (成品出貨時,每箱之毛重應以實測重量為準)
 When the finished products have been made,stick the proper designation list on the box according to product demand.
 CT-1.6 Produce goods taiwan , CT-1.9 Produce goods shanghai. (CT-1.6出貨台灣OP · CT-1.9出貨上海SH)
 It doesn't influence the manner of packing with the gold-plated way to print word way.Can amalgamate.(印字方式跟鍍金方式不影響包裝方式,可以共用)

歐品電子(昆山)有限公司

OUPIIN ELECTRONIC(KUNSHAN) CO.,LTD.

PACKAGING SPECIFICATION (包裝作業規範)

<input checked="" type="checkbox"/> CONFIDENTIAL		<input type="checkbox"/> TOP SECRET	
PAGE:	5/6	REV.	E

SPEC.NO.(規範編號)		Q2041SPP-348									
PACKING MATERIAL (包裝材料)			PRODUCT P/N	CT NO.	PACKING N.W.	PACKING QUANTITY (包裝數量)			WEIGHT (重量) kg		
MATERIAL NAME (材料名稱)	PART NO. (料號)	Q'TY	(產品料號)	(紙箱規格)	(包材重量)	PCS/TRAY	TRAY/BOX	PCS/BOX	N.W./PCS	N.W./BOX	G.W./BOX
PAPER BOXES (紙箱)	CT-0.9	1	2041-1x18GxxRA	CT-0.9	0.60	48	60	2880	0.001395	4.02	4.62
Packing Box (包裝盒)	PVC-2041-01	---	2041-1x19GxxRA	CT-0.9	0.60	48	60	2880	0.0014725	4.24	4.84
			2041-1x20GxxRA	CT-0.9	0.60	48	60	2880	0.00155	4.46	5.06
			2041-1X21GxxRA	CT-0.9	0.60	36	60	2160	0.0016275	3.52	4.12
Packing Box Cover (包裝盒蓋子)	PVC-2041-02	---	2041-1X22GxxRA	CT-0.9	0.60	36	60	2160	0.001705	3.68	4.28
			2041-1x23GxxRA	CT-0.9	0.60	36	60	2160	0.0017825	3.85	4.45
			2041-1x24GxxRA	CT-0.9	0.60	36	60	2160	0.00186	4.02	4.62
WATERPROOF BAG (防水袋)	PE 100*90	1	2041-1x25GxxRA	CT-0.9	0.60	36	60	2160	0.0019375	4.19	4.79
			2041-1X26GxxRA	CT-0.9	0.60	36	60	2160	0.002015	4.35	4.95
			2041-1X27GxxRA	CT-0.9	0.60	24	60	1440	0.0020925	3.01	3.61
Foam (保麗龍)	-----	2	2041-1x28GxxRA	CT-0.9	0.60	24	60	1440	0.00217	3.12	3.72
			2041-1x29GxxRA	CT-0.9	0.60	24	60	1440	0.0022475	3.24	3.84
			2041-1x30GxxRA	CT-0.9	0.60	24	60	1440	0.002325	3.35	3.95
DRYING AGENT (干燥劑)	-----	3	2041-1X31GxxRA	CT-0.9	0.60	24	60	1440	0.0024025	3.46	4.06
			2041-1X32GxxRA	CT-0.9	0.60	24	60	1440	0.00248	3.57	4.17
			2041-1X33GxxRA	CT-0.9	0.60	24	60	1440	0.0025575	3.68	4.28

1.NOTE:
 (注意) When the finished products have been made,take the actual weight as the standard of gross weight in each box.
 (成品出貨時,每箱之毛重應以實測重量為準)
 When the finished products have been made,stick the proper designation list on the box according to product demand.
 CT-1.6 Produce goods taiwan , CT-1.9 Produce goods shanghai. (CT-1.6出貨台灣OP , CT-1.9出貨上海SH)
 It doesn't influence the manner of packing with the gold-plated way to print word way,Can amalgamate.(印字方式跟鍍金方式不影響包裝方式,可以共用)

歐品電子(昆山)有限公司

OUPIIN ELECTRONIC(KUNSHAN) CO.,LTD.

PACKAGING SPECIFICATION (包裝作業規範)

<input checked="" type="checkbox"/> CONFIDENTIAL		<input type="checkbox"/> TOP SECRET	
PAGE:	6/6	REV.	E

SPEC.NO.(規範編號)		Q2041SPP-348									
PACKING MATERIAL (包裝材料)				PRODUCT P/N	CT NO.	PACKING N.W.	PACKING QUANTITY (包裝數量)			WEIGHT (重量) kg	
MATERIAL NAME (材料名稱)	PART NO. (料號)	Q'TY	(產品料號)	(紙箱規格)	(包材重量)	PCS/TRAY	TRAY/BOX	PCS/BOX	N.W./PCS	N.W./BOX	G.W./BOX
PAPER BOXES (紙箱)	CT-0.9	1	2041-1x34GxxRA	CT-0.9	0.60	24	60	1440	0.002635	3.79	4.39
Packing Box (包裝盒)	PVC-2041-01	----	2041-1x35GxxRA	CT-0.9	0.60	24	60	1440	0.0027125	3.91	4.51
			2041-1x36GxxRA	CT-0.9	0.60	24	60	1440	0.00279	4.02	4.62
			2041-1X37GxxRA	CT-0.9	0.60	24	60	1440	0.0028675	4.13	4.73
			2041-1X38GxxRA	CT-0.9	0.60	24	60	1440	0.002945	4.24	4.84
Packing Box Cover (包裝盒蓋子)	PVC-2041-02	----	2041-1x39GxxRA	CT-0.9	0.60	24	60	1440	0.0030225	4.35	4.95
			2041-1x40GxxRA	CT-0.9	0.60	24	60	1440	0.0031	4.46	5.06
WATERPROOF BAG (防水袋)	PE 100*90	1									
Foam (保麗龍)	-----	2									
DRYING AGENT (干燥劑)	-----	3									

1.NOTE:
 (注意) When the finished products have been made,take the actual weight as the standard of gross weight in each box.
 (成品出貨時,每箱之毛重應以實測重量為準)
 When the finished products have been made,stick the proper designation list on the box according to product demand.
 CT-1.6 Produce goods taiwan , CT-1.9 Produce goods shanghai. (CT-1.6出貨台灣OP , CT-1.9出貨上海SH)
 It doesn't influence the manner of packing with the gold-plated way to print word way,Can amalgamate.(印字方式跟鍍金方式不影響包裝方式,可以共用)