

歐品電子(昆山)有限公司

OUPIIN ELECTRONIC(KUNSHAN) CO.,LTD.

PACKAGING SPECIFICATION (包裝作業規範)

CONFIDENTIAL TOP SECRET

SPEC.NO.(規範編號) Q2047SPP-818		APPLICABLE PRODUCT (適用產品) 2047-1XxxGxxS11U		PAGE 1/6	REV. A
APPLICABLE CUSTOMER (適用客戶) ALL				PACKAGING CATEGORY (包裝方式)	TUBE PACKING

REVISION HISTORY (修訂履歷)

ECN REV. NO	PAGE (頁次)								
	1	2	3	4					
A	New issue . (新版發行.)								

DIVISION (事業單位) Product Development (產品開發課)	APPROVED (核准)	CHECKED (審核)	PREPARED (制表) zbs 12/06'14
---	---------------	--------------	----------------------------

歐品電子(昆山)有限公司

OUPIIN ELECTRONIC(KUNSHAN) CO.,LTD.

PACKAGING SPECIFICATION (包裝作業規範)

SPEC.NO.(規範編號) Q2047SPP-818

<input checked="" type="checkbox"/> CONFIDENTIAL		<input type="checkbox"/> TOP SECRET	
PAGE	2/6	REV.	A

PACKING OPERATION DIAGRAM & INSTRUCTION (包裝作業圖示及說明)

REMARK (備注)

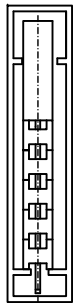

Drawing One: Product Installing Mode
(圖一產品裝入方式)

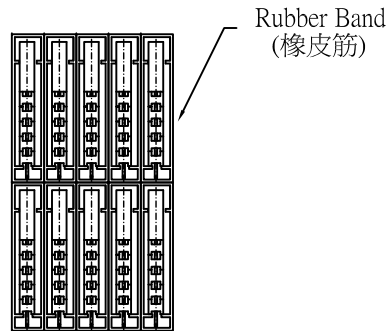

Drawing Two: Each Bundle Ten Tube
(圖二: 每10管為1捆)

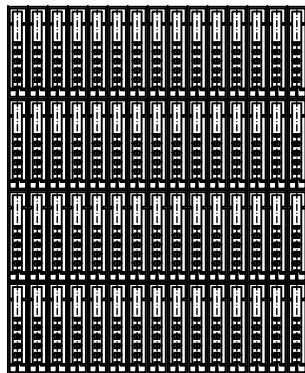

Drawing Three:Lay three bundles in each layer.Install in two layers.Six bundles, Sixty tubes in all.

(圖3)每層放3捆。分2層放入,一盒共6捆,共60管)

Disposing schematic diagram of Tube in the inner box, for reference.

(管在內盒的擺放示意圖,供參考)

一.Inner box packing mode: (內盒包裝方式)

(1).Each tube packing mode:Stuff one end of tube with stopper, stuff the other end of the tube after load into definite quality of product, as shown in drawing One.And stuffing in stopper,the end of the stopper must be level with the tube mouth, can't be shown.

(每管包裝方式:用塞子塞住管子一頭,放入一定數量產品後,塞住另一頭,裝入方式如(圖一)所示.且塞子塞入後,末端要和管口平齊,不可外露.)

(2).Devide each ten tube product in two layers, laying mode:As shown in Drawing Two, the two ends are away from tube mouth 50mm, fix them with 1PCS rubber band.

(每10管產品分2層,放置方式:如(圖2)所示,兩頭離管口50mm處,各用1PCS橡皮筋纏2道固定.)

(3).Lay six bundles in one case with two layers, three bundles in one layer ,60 tubes in all. As shown in drawing Three.

(一盒6捆分2層放入,每層放3捆。共60管。如(圖三)所示)

歐品電子(昆山)有限公司

OUPIIN ELECTRONIC(KUNSHAN) CO.,LTD.

PACKAGING SPECIFICATION (包裝作業規範)

<input checked="" type="checkbox"/> CONFIDENTIAL		<input type="checkbox"/> TOP SECRET	
PAGE	3/6	REV.	A

SPEC.NO.(規範編號) Q2047SPP-818

PACKING OPERATION DIAGRAM & INSTRUCTION (包裝作業圖示及說明)

REMARK (備注)

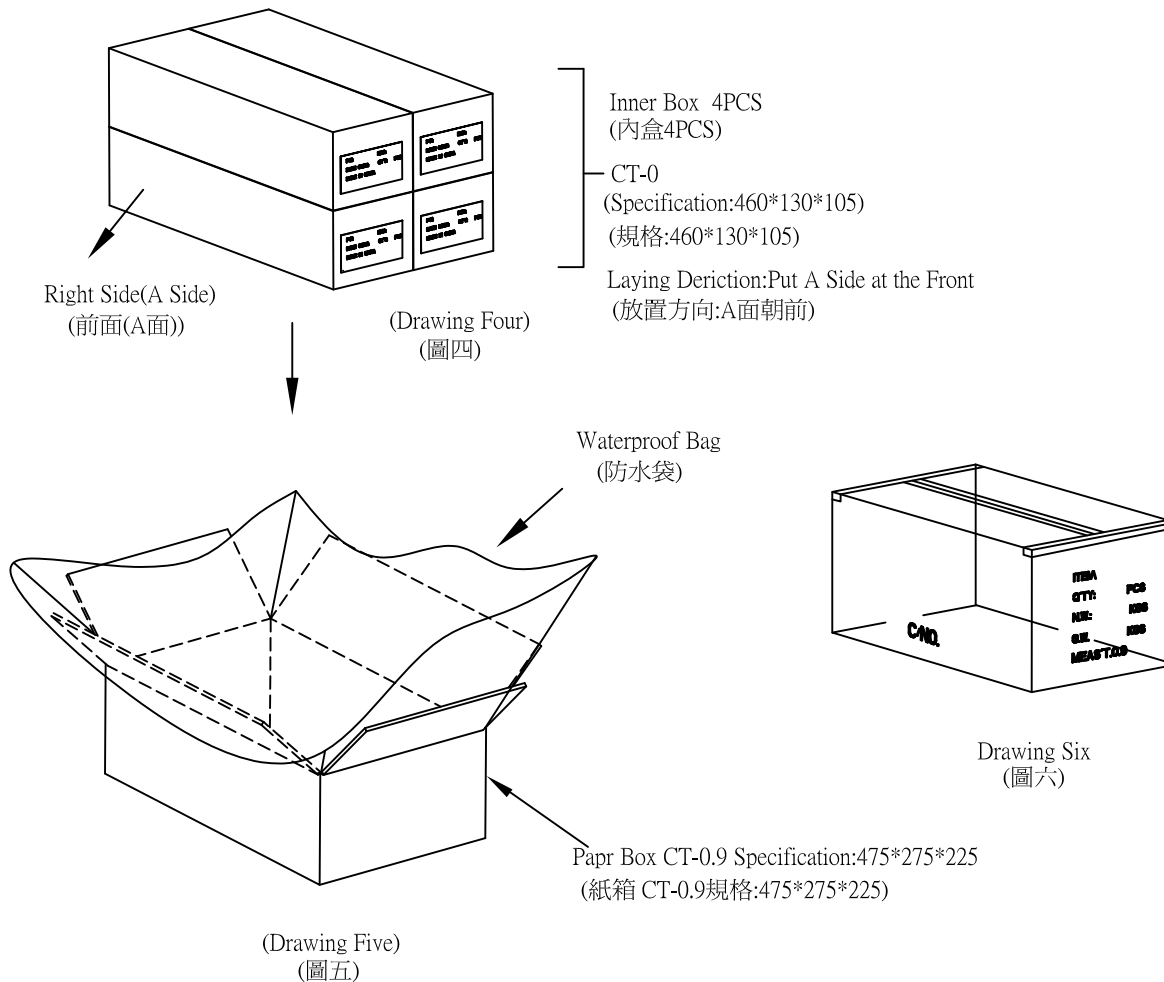

二.Outer box packing mode: (外箱包裝方式)

- (1).Paper box CT-0.9 Standart 1 PCS.
(紙箱CT-0.9規格 1 PCS.)
- (2).Put waterproof bag 1 PCS in the paper box.
(紙箱內側放入防水袋 1 PCS.)
- (3).Put 4PCS inner box filled with product in the waterproof bag.
(于防水袋內放入4PCS裝滿產品之內盒.)
- (4).Laying mode of the four inner boxes is that A side in front side.,
the laying mode of the four inner boxes must in one direction.
(四個內盒的放置方式為1面朝前放置,四內盒放置方向須一致.)
- (5).The detailed specification of inner box is shown in page two.
(內盒之詳細包裝規範如第2頁.)
- (6).After laying inner boxes, tie the waterproof bag tightly.Seal the
surface of the outer box.(Drawing Six)
(放好內盒,扎緊防水袋。將外箱上層封口。(圖六))

The form on the right and flank side of the bo must be filled correctly
and clearly, take actual testing weight as the standard of every box
gross weight.
(外箱之正麥和側麥所要填寫之項目要填寫正確,清晰,每箱之
毛重應以實測重量為準.)

歐品電子(昆山)有限公司

OUPIIN ELECTRONIC(KUNSHAN) CO.,LTD.

PACKAGING SPECIFICATION (包裝作業規範)

CONFIDENTIAL TOP SECRET

SPEC.NO.(規範編號)		Q2047SPP-818								PAGE:	4/6	REV.	A
PACKING MATERIAL (包裝材料)			PRODUCT P/N	PACKING N.W.	PACKING QUANTITY (包裝數量)					WEIGHT (重量) kg			
MATERIAL NAME (材料名稱)	PART NO. (料號)	Q'TY	(產品料號)	(包材重量)	PCS/TUBE	TUBE/INNER BOX	PCS/INNER BOX	INNER BOX/BOX	PCS/BOX	N.W./PCS	N.W./BOX	G.W./BOX	
PAPER BOXES (紙箱)	CT-0.9	1	2047-1X02GxxS11U	7.33	78	60	4680	4	18720	0.000446	8.35	15.68	
PACKING INNER BOX (內紙箱)	CT-0	4	2047-1X03GxxS11U	7.33	53	60	3180	4	12720	0.000669	8.51	15.84	
			2047-1X04GxxS11U	7.33	40	60	2400	4	9600	0.000892	8.56	15.90	
			2047-1X05GxxS11U	7.33	32	60	1920	4	7680	0.001115	8.56	15.90	
TUBE (管子)	TUBE-2047-15	240	2047-1X06GxxS11U	7.33	27	60	1620	4	6480	0.001338	8.67	16.00	
			2047-1X07GxxS11U	7.33	23	60	1380	4	5520	0.001561	8.62	15.95	
			2047-1X08GxxS11U	7.33	20	60	1200	4	4800	0.001784	8.56	15.90	
TUBE PLUG (塞子)	-----	480	2047-1X09GxxS11U	7.33	19	60	1140	4	4560	0.002007	9.15	16.48	
			2047-1X10GxxS11U	7.33	16	60	960	4	3840	0.00223	8.56	15.90	
			2047-1X11GxxS11U	7.33	15	60	900	4	3600	0.002453	8.83	16.16	
WATERPROFF BAG (防水袋)	PE100*70	1	2047-1X12GxxS11U	7.33	13	60	780	4	3120	0.002676	8.35	15.68	
			2047-1X13GxxS11U	7.33	12	60	720	4	2880	0.002899	8.35	15.68	
			2047-1X14GxxS11U	7.33	11	60	660	4	2640	0.003122	8.24	15.57	
DRYING AGENT (干燥劑)	-----	3	2047-1X15GxxS11U	7.33	11	60	660	4	2640	0.003345	8.83	16.16	
			2047-1X16GxxS11U	7.33	10	60	600	4	2400	0.003568	8.56	15.90	
RUBBER RIBE (橡皮筋)	-----	48	2047-1X17GxxS11U	7.33	9	60	540	4	2160	0.003791	8.19	15.52	
			2047-1X18GxxS11U	7.33	9	60	540	4	2160	0.004014	8.67	16.00	
			2047-1X19GxxS11U	7.33	8	60	480	4	1920	0.004237	8.14	15.47	

1.NOTE:

(注意)

When the finished products have been made,take the actual weight as the standard of gross weight in each box.

(成品出貨時,每箱之毛重應以實測重量為準)

When the finished products have been made,stick the proper designation list on the box according to product demand.

(成品出貨時,依據出貨要求貼上相對應的標籤單)

歐品電子(昆山)有限公司

OUPIIN ELECTRONIC(KUNSHAN) CO.,LTD.

PACKAGING SPECIFICATION (包裝作業規範)

CONFIDENTIAL TOP SECRET

SPEC.NO.(規範編號)		Q2047SPP-818								PAGE:	5/6	REV.	A
PACKING MATERIAL (包裝材料)			PRODUCT P/N	PACKING N.W.	PACKING QUANTITY (包裝數量)					WEIGHT (重量) kg			
MATERIAL NAME (材料名稱)	PART NO. (料號)	Q'TY	(產品料號)	(包材重量)	PCS/TUBE	TUBE/INNER BOX	PCS/INNER BOX	INNER BOX/BOX	PCS/BOX	N.W./PCS	N.W./BOX	G.W./BOX	
PAPER BOXES (紙箱)	CT-0.9	1	2047-1X20GxxS11U	7.33	8	60	480	4	1920	0.00446	8.56	15.90	
PACKING INNER BOX (內紙箱)	CT-0	4	2047-1X21GxxS11U	7.33	8	60	480	4	1920	0.004683	8.99	16.32	
			2047-1X22GxxS11U	7.33	7	60	420	4	1680	0.004906	8.24	15.57	
			2047-1X23GxxS11U	7.33	7	60	420	4	1680	0.005129	8.62	15.95	
TUBE (管子)	TUBE-2047-15	240	2047-1X24GxxS11U	7.33	7	60	420	4	1680	0.005352	8.99	16.32	
			2047-1X25GxxS11U	7.33	6	60	360	4	1440	0.005575	8.03	15.36	
			2047-1X26GxxS11U	7.33	6	60	360	4	1440	0.005798	8.35	15.68	
TUBE PLUG (塞子)	-----	480	2047-1X27GxxS11U	7.33	6	60	360	4	1440	0.006021	8.67	16.00	
			2047-1X28GxxS11U	7.33	6	60	360	4	1440	0.006244	8.99	16.32	
			2047-1X29GxxS11U	7.33	5	60	300	4	1200	0.006467	7.76	15.09	
WATERPROFF BAG (防水袋)	PE100*70	1	2047-1X30GxxS11U	7.33	5	60	300	4	1200	0.00669	8.03	15.36	
			2047-1X31GxxS11U	7.33	5	60	300	4	1200	0.006913	8.30	15.63	
			2047-1X32GxxS11U	7.33	5	60	300	4	1200	0.007136	8.56	15.90	
DRYING AGENT (干燥劑)	-----	3	2047-1X33GxxS11U	7.33	5	60	300	4	1200	0.007359	8.83	16.16	
			2047-1X34GxxS11U	7.33	4	60	240	4	960	0.007582	7.28	14.61	
RUBBER RIBE (橡皮筋)	-----	48	2047-1X35GxxS11U	7.33	4	60	240	4	960	0.007805	7.49	14.82	
			2047-1X36GxxS11U	7.33	4	60	240	4	960	0.008028	7.71	15.04	
			2047-1X37GxxS11U	7.33	4	60	240	4	960	0.008251	7.92	15.25	

1.NOTE:

(注意)

When the finished products have been made,take the actual weight as the standard of gross weight in each box.

(成品出貨時,每箱之毛重應以實測重量為準)

When the finished products have been made,stick the proper designation list on the box according to product demand.

(成品出貨時,依據出貨要求貼上相對應的標籤單)

歐品電子(昆山)有限公司

OUPIIN ELECTRONIC(KUNSHAN) CO.,LTD.

PACKAGING SPECIFICATION (包裝作業規範)

CONFIDENTIAL TOP SECRET

SPEC.NO.(規範編號)		Q2047SPP-818								PAGE:	6/6	REV.	A
PACKING MATERIAL (包裝材料)			PRODUCT P/N	PACKING N.W.	PACKING QUANTITY (包裝數量)					WEIGHT (重量) kg			
MATERIAL NAME (材料名稱)	PART NO. (料號)	Q'TY	(產品料號)	(包材重量)	PCS/TUBE	TUBE/INNER BOX	PCS/INNER BOX	INNER BOX/BOX	PCS/BOX	N.W./PCS	N.W./BOX	G.W./BOX	
PAPER BOXES (紙箱)	CT-0.9	1	2047-1X38GxxS11U	7.33	4	60	240	4	960	0.008474	8.14	15.47	
PACKING INNER BOX (內紙箱)	CT-0	4	2047-1X39GxxS11U	7.33	4	60	240	4	960	0.008697	8.35	15.68	
			2047-1X40GxxS11U	7.33	4	60	240	4	960	0.00892	8.56	15.90	
TUBE (管子)	TUBE-2047-15	240											
TUBE PLUG (塞子)	-----	480											
WATERPROFF BAG (防水袋)	PE100*70	1											
DRYING AGENT (干燥劑)	-----	3											
RUBBER RIBE (橡皮筋)	-----	48											

1.NOTE:

(注意)

When the finished products have been made,take the actual weight as the standard of gross weight in each box.

(成品出貨時,每箱之毛重應以實測重量為準)

When the finished products have been made,stick the proper designation list on the box according to product demand.

(成品出貨時,依據出貨要求貼上相對應的標籤單)