

歐品電子(昆山)有限公司

OUPIN ELECTRONIC(KUNSHAN) CO.,LTD.

PACKAGING SPECIFICATION (包裝作業規範)

CONFIDENTIAL TOP SECRET

SPEC.NO.(規範編號) Q2049SPP-151				PAGE	1/6	REV.	H
APPLICABLE CUSTOMER (適用客戶)	ALL	APPLICABLE PRODUCT (適用產品)	2049-1XxxGxxU 2049-1X05GxxU/A001 2049-1X04GxxU/A002 2049-1X14GxxU/A004	PACKAGING CATEGORY (包裝方式)		TUBE PACKING	

REVISION HISTORY (修訂履歷)

REV. / ECN NO	PAGE (頁次)								
	1	2	3	4	5	6			
F	Add 2049-1X04GxxU/A002 增加 2049-1X04GxxU/A002								
G	Add 2049-1X14GxxU/A004 增加 2049-1X14GxxU/A004								
H	Add 2049-1X04GxxU/A004 增加 2049-1X04GxxU/A004								

DIVISION (事業單位)	Product Development (產品開發課)	APPROVED (核准)		CHECKED (審核)	DE: PE:	PREPARED (制表)	WW 06/16'21
-----------------	-----------------------------	---------------	--	--------------	------------	---------------	-------------

歐品電子(昆山)有限公司

OUPIIN ELECTRONIC(KUNSHAN) CO.,LTD.

PACKAGING SPECIFICATION (包裝作業規範)

<input checked="" type="checkbox"/> CONFIDENTIAL		<input type="checkbox"/> TOP SECRET	
PAGE	3/6	REV.	H

SPEC.NO.(規範編號) Q2049SPP-151

PACKING OPERATION DIAGRAM & INSTRUCTION (包裝作業圖示及說明)	REMARK (備注)
---	-------------

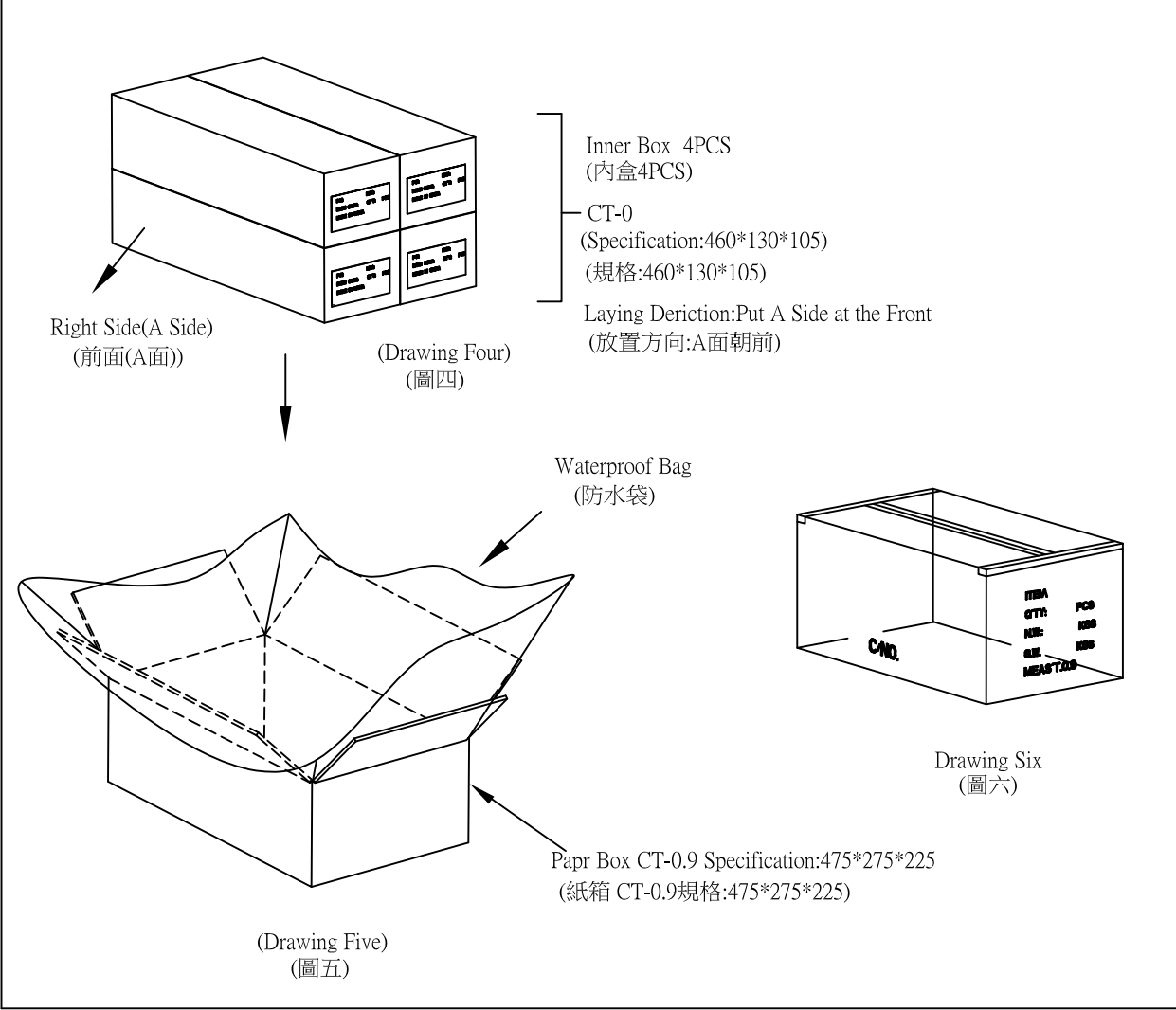

二.Outer box packing mode:
(外箱包裝方式)

- (1).Paper box CT-0.9 Standart 1 PCS.
(紙箱CT-0.9規格 1 PCS.)
- (2).Put waterproof bag 1 PCS in the paper box.
(紙箱內側放入防水袋 1 PCS.)
- (3).Put 4PCS inner box filled with product in the waterproof bag.
(于防水袋內放入4PCS裝滿產品之內盒.)
- (4).Laying mode of the four inner boxes is that A side in front side.,
the laying mode of the four inner boxes must in one direction.
(四個內盒的放置方式為1面朝前放置,四內盒放置方向須一致.)
- (5).The detailed specification of inner box is shown in page two.
(內盒之詳細包裝規範如第2頁.)
- (6).After laying inner boxes, tie the waterproof bag tightly.Seal the
surface of the outer box.(Drawing Six)
(放好內盒,扎緊防水袋。將外箱上層封口。(圖六))

The form on the right and flank side of the bo must be filled correctly
and clearly, take actual testing weight as the standard of every box
gross weight.
(外箱之正麥和側麥所要填寫之項目要填寫正確,清晰,每箱之
毛重應以實測重量為準.)

歐品電子(昆山)有限公司

OUPIIN ELECTRONIC(KUNSHAN) CO.,LTD.

PACKAGING SPECIFICATION (包裝作業規範)

SPEC.NO.(規範編號) Q2049SPP-151

<input checked="" type="checkbox"/> CONFIDENTIAL <input type="checkbox"/> TOP SECRET			
PAGE	2/6	REV.	G

PACKING OPERATION DIAGRAM & INSTRUCTION (包裝作業圖示及說明)

REMARK (備注)

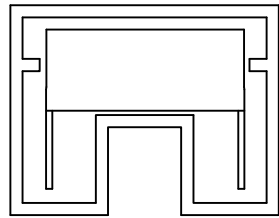

Drawing One: Product Installing Mode
(圖一產品裝入方式)

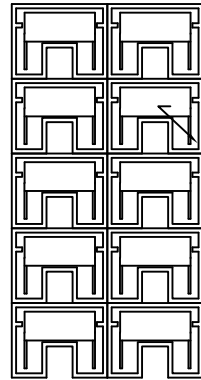

Drawing Two: Each Bundle 10 Tube
(圖二: 每10管為1捆)

Rubber Band
(橡皮筋)

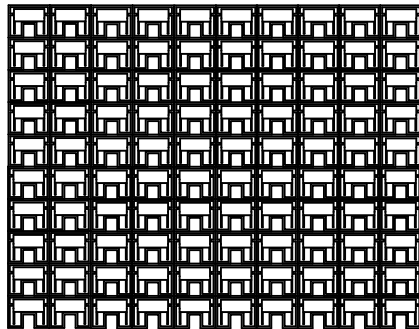

Drawing Three: Lay 5 bundles in each layer. Install in 2 layers. 10 bundles, 100 tubes in all.
(圖3)每層放5捆。分2層放入,一盒共10捆,共100管)
Disposing schematic diagram of Tube in the inner box, for reference.
(管在內盒的擺放示意圖,供參考)

一.Inner box packing mode: (內盒包裝方式)

- (1).Each tube packing mode:Stuff one end of tube with stopper, stuff the other end of the tube after load into definite quality of product, as shown in drawing One.And stuffing in stopper,the end of the stopper must be level with the tube mouth, can't be shown.
(每管包裝方式:用塞子塞住管子一頭,放入一定數量產品後,塞住另一頭,裝入方式如(圖一)所示.且塞子塞入後,末端要和管口平齊,不可外露.)
- (2).Devide each 10 tube product in 5 layers, laying mode:As shown in Drawing Two, the two ends are away from tube mouth 50mm, fix them with 1PCS rubber band.
(每10管產品分5層,放置方式:如(圖二)所示,兩頭離管口50mm處,各用1PCS橡皮筋纏2道固定.)
- (3).Lay 10 bundles in one case with 2 layers, 5 bundles in one layer ,100 tubes in all. As shown in drawing Three.
(一盒10捆分2層放入,每層放5捆。共100管。如(圖三)所示)

歐品電子(昆山)有限公司

OUPIIN ELECTRONIC(KUNSHAN) CO.,LTD.

PACKAGING SPECIFICATION (包裝作業規範)

CONFIDENTIAL TOP SECRET

SPEC.NO.(規範編號) Q2049SPP-151

PAGE: 4/6 REV. H

PACKING MATERIAL (包裝材料)			PRODUCT P/N	PACKING N.W.	PACKING QUANTITY (包裝數量)					WEIGHT (重量) kg		
MATERIAL NAME (材料名稱)	PART NO. (料號)	Q'TY	(產品料號)	(包材重量)	PCS/TUBE	TUBE/INNER BOX	PCS/INNER BOX	INNER BOX/BOX	PCS/BOX	N.W./PCS	N.W./BOX	G.W./BOX
PAPER BOXES (紙箱)	CT-0.9	1	2049-1X02GxxU	7.45	84	100	8400	4	33600	0.00023	7.73	15.18
PACKING INNER BOX (內紙箱)	CT-0	4	2049-1X03GxxU	7.45	56	100	5600	4	22400	0.000345	7.73	15.18
			2049-1X04GxxU	7.45	42	100	4200	4	16800	0.00046	7.73	15.18
			2049-1X05GxxU	7.45	33	100	3300	4	13200	0.000575	7.59	15.04
TUBE (管子)	TUBE-2049-01	400	2049-1X06GxxU	7.45	28	100	2800	4	11200	0.00069	7.73	15.18
			2049-1X07GxxU	7.45	24	100	2400	4	9600	0.000805	7.73	15.18
			2049-1X08GxxU	7.45	21	100	2100	4	8400	0.00092	7.73	15.18
TUBE PLUG (塞子)	-----	800	2049-1X09GxxU	7.45	18	100	1800	4	7200	0.001035	7.45	14.90
			2049-1X10GxxU	7.45	16	100	1600	4	6400	0.00115	7.36	14.81
			2049-1X11GxxU	7.45	15	100	1500	4	6000	0.001265	7.59	15.04
WATERPROFF BAG (防水袋)	PE100*70	1	2049-1X12GxxU	7.45	14	100	1400	4	5600	0.00138	7.73	15.18
			2049-1X13GxxU	7.45	13	100	1300	4	5200	0.001495	7.77	15.22
			2049-1X14GxxU(-A004)	7.45	12	100	1200	4	4800	0.00161	7.73	15.18
DRYING AGENT (干燥劑)	-----	3	2049-1X15GxxU	7.45	11	100	1100	4	4400	0.001725	7.59	15.04
			2049-1X16GxxU	7.45	10	100	1000	4	4000	0.00184	7.36	14.81
RUBBER RIBE (橡皮筋)	-----	800	2049-1X17GxxU	7.45	9	100	900	4	3600	0.001955	7.04	14.49
			2049-1X18GxxU	7.45	9	100	900	4	3600	0.00207	7.45	14.90
			2049-1X19GxxU	7.45	8	100	800	4	3200	0.002185	6.99	14.44

1.NOTE:
 (注意)
 When the finished products have been made,take the actual weight as the standard of gross weight in each box.
 (成品出貨時,每箱之毛重應以實測重量為準)
 When the finished products have been made,stick the proper designation list on the box according to product demand.
 (成品出貨時,依據出貨要求貼上相對應的標籤單)

歐品電子(昆山)有限公司

OUPIIN ELECTRONIC(KUNSHAN) CO.,LTD.

PACKAGING SPECIFICATION (包裝作業規範)

CONFIDENTIAL TOP SECRET

SPEC.NO.(規範編號)		Q2049SPP-151		PAGE:		5/6		REV.		H		
PACKING MATERIAL (包裝材料)			PRODUCT P/N	PACKING N.W.	PACKING QUANTITY (包裝數量)					WEIGHT (重量) kg		
MATERIAL NAME (材料名稱)	PART NO. (料號)	Q'TY	(產品料號)	(包材重量)	PCS/TUBE	TUBE/INNER BOX	PCS/INNER BOX	INNER BOX/BOX	PCS/BOX	N.W./PCS	N.W./BOX	G.W./BOX
PAPER BOXES (紙箱)	CT-0.9	1	2049-1X20GxxU	7.45	8	100	800	4	3200	0.0023	7.36	14.81
PACKING INNER BOX (內紙箱)	CT-0	4	2049-1X21GxxU	7.45	8	100	800	4	3200	0.002415	7.73	15.18
			2049-1X22GxxU	7.45	7	100	700	4	2800	0.00253	7.08	14.53
			2049-1X23GxxU	7.45	7	100	700	4	2800	0.002545	7.41	14.85
TUBE (管子)	TUBE-2049-01	400	2049-1X24GxxU	7.45	7	100	700	4	2800	0.00276	7.73	15.18
			2049-1X25GxxU	7.45	6	100	600	4	2400	0.002875	6.90	14.35
			2049-1X26GxxU	7.45	6	100	600	4	2400	0.00299	7.18	14.62
TUBE PLUG (塞子)	-----	800	2049-1X27GxxU	7.45	6	100	600	4	2400	0.003105	7.45	14.90
			2049-1X28GxxU	7.45	6	100	600	4	2400	0.00322	7.73	15.18
			2049-1X29GxxU	7.45	5	100	500	4	2000	0.003335	6.67	14.12
WATERPROFF BAG (防水袋)	PE100*70	1	2049-1X30GxxU	7.45	5	100	500	4	2000	0.00345	6.90	14.35
			2049-1X31GxxU	7.45	5	100	500	4	2000	0.003565	7.13	14.58
			2049-1X32GxxU	7.45	5	100	500	4	2000	0.00368	7.36	14.81
DRYING AGENT (干燥劑)	-----	3	2049-1X33GxxU	7.45	5	100	500	4	2000	0.003795	7.59	15.04
			2049-1X34GxxU	7.45	4	100	400	4	1600	0.00391	6.26	13.70
RUBBER RIBE (橡皮筋)	-----	800	2049-1X35GxxU	7.45	4	100	400	4	1600	0.004025	6.44	13.89
			2049-1X36GxxU	7.45	4	100	400	4	1600	0.00414	6.62	14.07
			2049-1X05GxxU/A001	7.45	33	100	3300	4	13200	0.000575	7.59	15.04

1.NOTE:
 (注意)
 When the finished products have been made,take the actual weight as the standard of gross weight in each box.
 (成品出貨時,每箱之毛重應以實測重量為準)
 When the finished products have been made,stick the proper designation list on the box according to product demand.
 (成品出貨時,依據出貨要求貼上相對應的標籤單)

歐品電子(昆山)有限公司

OUPIIN ELECTRONIC(KUNSHAN) CO.,LTD.

PACKAGING SPECIFICATION (包裝作業規範)

CONFIDENTIAL TOP SECRET

PAGE: 6/6 REV. H

SPEC.NO.(規範編號)		Q2049SPP-151										
PACKING MATERIAL (包裝材料)			PRODUCT P/N	PACKING N.W.	PACKING QUANTITY (包裝數量)					WEIGHT (重量) kg		
MATERIAL NAME (材料名稱)	PART NO. (料號)	Q'TY	(產品料號)	(包材重量)	PCS/TUBE	TUBE/INNER BOX	PCS/INNER BOX	INNER BOX/BOX	PCS/BOX	N.W./PCS	N.W./BOX	G.W./BOX
PAPER BOXES (紙箱)	CT-0.9	1	2049-1X04GxxU/A002	7.45	42	100	4200	4	16800	0.00034	5.71	13.16
PACKING INNER BOX (內紙箱)	CT-0	4	2049-1X04GxxU/A004	7.45	42	100	4200	4	16800	0.00034	5.71	13.16
TUBE (管子)	TUBE-2049-01	400										
TUBE PLUG (塞子)	-----	800										
WATERPROFF BAG (防水袋)	PE100*70	1										
DRYING AGENT (干燥劑)	-----	3										
RUBBER RIBE (橡皮筋)	-----	800										

1.NOTE:

(注意)

When the finished products have been made,take the actual weight as the standard of gross weight in each box.

(成品出貨時,每箱之毛重應以實測重量為準)

When the finished products have been made,stick the proper designation list on the box according to product demand.

(成品出貨時,依據出貨要求貼上相對應的標籤單)