

歐品電子(昆山)有限公司

OUPIIN ELECTRONIC(KUNSHAN) CO.,LTD.

PACKAGING SPECIFICATION (包裝作業規範)

<input checked="" type="checkbox"/> CONFIDENTIAL <input type="checkbox"/> TOP SECRET			
PAGE	1/3	REV.	A

SPEC.NO.(規範編號)	Q4191SPP-951
----------------	--------------

APPLICABLE CUSTOMER (適用客戶)	ALL	APPLICABLE PRODUCT (適用產品)	4191-MEC1SR
----------------------------------	-----	---------------------------------	-------------

PACKAGING CATEGORY (包裝方式)	TUBE PACKING
---------------------------------	--------------

REVISION HISTORY (修訂履歷)

ECN NO. REV.	PAGE (頁次)							
	1	2	3	4				
A	New (新發行)							

DIVISION (事業單位)	Product Development (產品開發課)	APPROVED (核准)	CHECKED (審核)	PREPARED (制表)	YW12/23'16
--------------------	--------------------------------	------------------	-----------------	------------------	------------

歐品電子(昆山)有限公司

OUPIIN ELECTRONIC(KUNSHAN) CO.,LTD.

PACKAGING SPECIFICATION (包裝作業規範)

CONFIDENTIAL TOP SECRET

SPEC.NO.(規範編號) Q4191SPP-951

PAGE

2/3

REV.

A

PACKING OPERATION DIAGRAM & INSTRUCTION (包裝作業圖示及說明)

REMARK (備注)

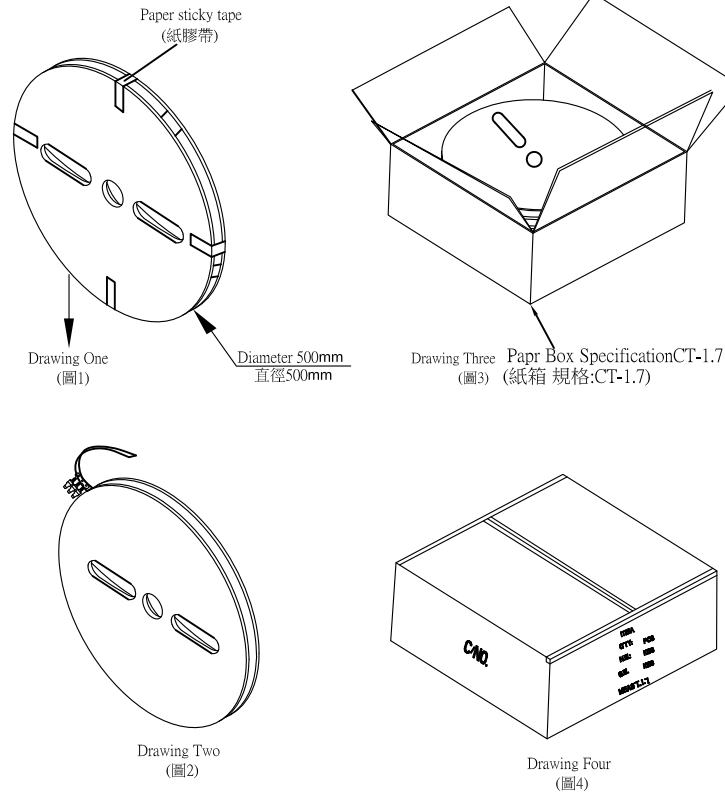

三.Outer box packing mode:

(外箱包裝方式)

- (1).Paper box CT-1.7 Standart 1 PCS.Diameter 500mm of the paper dish 4 pcs as shown in drawing one
(紙箱規格CT-1.7 1 PCS,紙盤直徑500mm 4 PCS如(圖一)所示)
- (2).Put waterproof bag 1 PCS in the paper box.
(紙箱內側放入防水袋 1 PCS.)
- (2).4191-MEC1SR Produce the goods with the case every roll 35K PCS,as shown in diagram.(Drawing 4191-MEC1SR 以箱子出貨,每卷35K PCS.)
- (3).Fill the paper dish with the end son, seal everywhere with the paper sticky tape,as shown in drawing Two
(將紙盤裝滿端子,用紙膠帶封住四處封口.如(圖二)所示)
- (4). Every four hold a case Each put 30mm foam plank in material both ends (Drawing Three)(Put 1 PCS Foam Board at the Upper and lower in the paper box if it is necessary.)
(每4卷裝一箱.料盤兩頭各放10mm保麗龍(圖三))(必要時,在紙箱的上下兩邊各放一塊保麗龍)
- (5). Seal the surface of the outer box.(Drawing Ten)
(將外箱上層封口.(圖四))

The form on the right and flank side of the bo must be filled correctly and clearly, take actual testing weight as the standard of every box gross weight.

(外箱之正麥和側麥所要填寫之項目要填寫正確,清晰,每箱之毛重應以實測重量為準.)

歐品電子(昆山)有限公司

OUPIN ELECTRONIC(KUNSHAN) CO.,LTD.

PACKAGING SPECIFICATION (包裝作業規範)

CONFIDENTIAL TOP SECRET

SPEC.NO.(規範編號)

Q4191SPP-951

PAGE:

3/3

REV.

A

PACKING MATERIAL (包裝材料)

PRODUCT P/N

PACKING N.W.

PACKING QUANTITY (包裝數量)

WEIGHT (重量) kg

MATERIAL NAME
(材料名稱)

PART NO. (料號)

Q'TY

(產品料號)

(包材重量)

PCS/REEL

REEL/BOX

PCS/BOX

N.W./PCS

N.W./BOX

G.W./BOX

PAPER BOXES (紙箱)

CT-1.7

1

4191-MEC1SR

3.52

15000

4

60000

0.000187

11.19

14.71

保麗龍(Foam board)

10mm

2

WATERPROFF BAG
(防水袋)

PE100*71

1

DRYING AGENT
(干燥劑)

3

1.NOTE:

(注意) When the finished products have been made, every roll 10K PCS add 100pcs , total number 6.1K

(成品出貨時, 每卷數量加100pcs, 每卷總數為6.1K)

(注意) When the finished products have been made,take the actual weight as the standard of gross weight in each box.

(成品出貨時,每箱之毛重應以實測重量為準)

When the finished products have been made,stick the proper designation list on the box according to product demand.

(成品出貨時,依據出貨要求貼上相對應的標籤單)

CT-1.6 Produce goods taiwan , CT-1.9 Produce goods shanghai. (CT-1.6出貨台灣OP, CT-1.9出貨上海SH)

It doesn't influence the manner of packing with the gold-plated way to print word way.Can amalgamate.(印字方式跟鍍金方式不影響包裝方式, 可以共用)