

歐品電子(昆山)有限公司

OUPIN ELECTRONIC(KUNSHAN) CO.,LTD.

PACKAGING SPECIFICATION (包裝作業規範)

SPEC.NO.(規範編號)	4077SPP-SB	適用產品: 4077-03G00SB	PAGE	1/1	REV.	I704-A
----------------	------------	--------------------	------	-----	------	--------

PACKING OPERATION DIAGRAM & INSTRUCTION (包裝作業圖示及說明)	REMARK (備註)
---	-------------

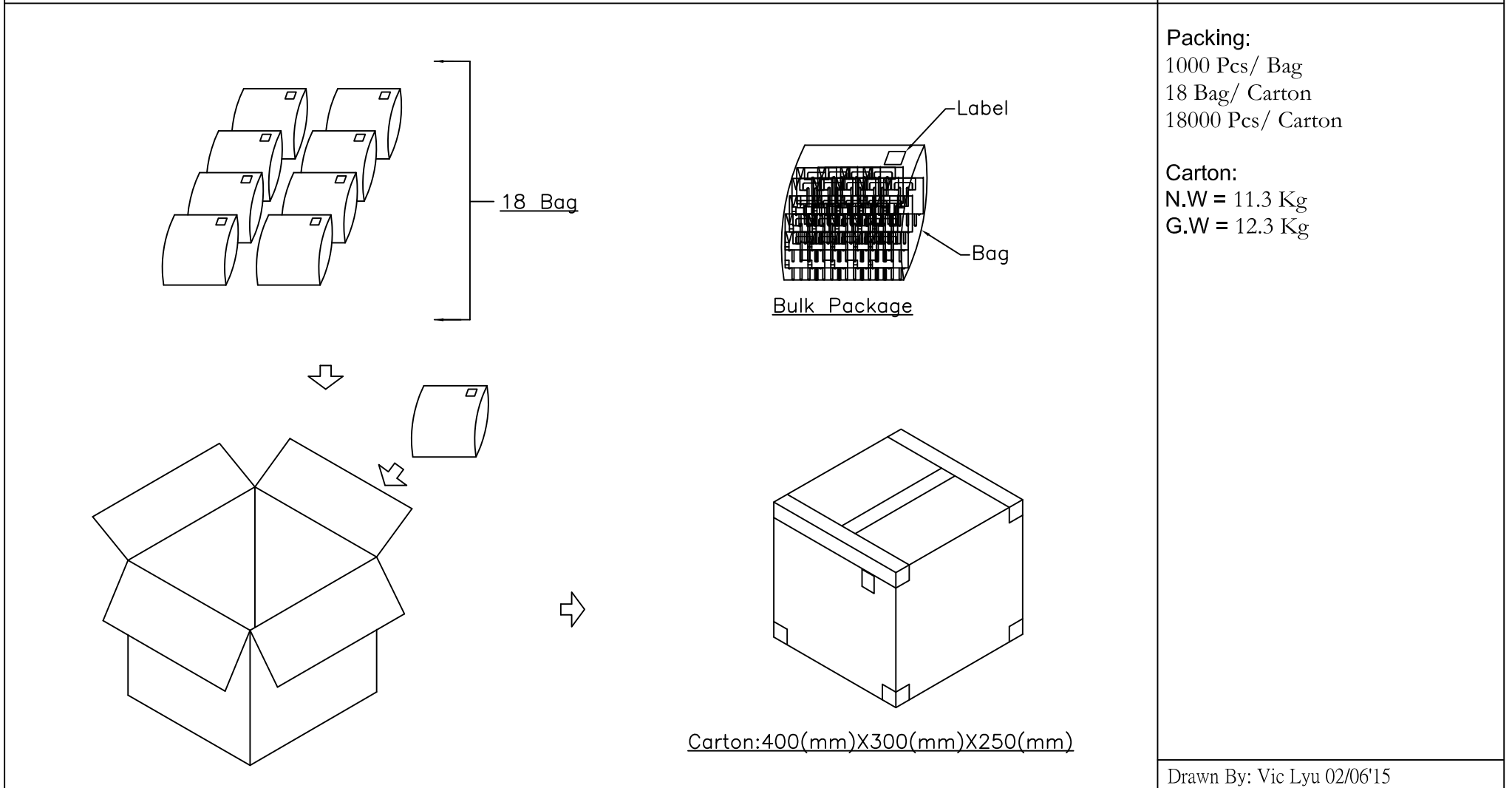

Packing:
1000 Pcs/ Bag
18 Bag/ Carton
18000 Pcs/ Carton

Carton:
N.W = 11.3 Kg
G.W = 12.3 Kg

Drawn By: Vic Lyu 02/06'15