

# 歐品電子(昆山)有限公司

OUPIN ELECTRONIC(KUNSHAN) CO.,LTD.

PACKAGING SPECIFICATION (包裝作業規範)

CONFIDENTIAL  TOP SECRET

SPEC.NO.(規範編號) Q9001SPP-1270T1		APPLICABLE PRODUCT (適用產品) 9001-52151xA		PAGE 1/4	REV. A
APPLICABLE CUSTOMER (適用客戶) ALL				PACKAGING CATEGORY (包裝方式) TRAY PLATE PACKING	

## REVISION HISTORY (修訂履歷)

ECN NO. REV.	PAGE (頁次)							
	1	2	3	4				
A	New 新版發行.							

DIVISION (事業單位) Product Development (產品開發課)	APPROVED (核准) Peter Zhu	CHECKED (審核) Nita Lu	PREPARED (制表) Martin 06/07'23
---	-------------------------	----------------------	-------------------------------

# 歐品電子(昆山)有限公司

OUPIIN ELECTRONIC(KUNSHAN) CO.,LTD.

PACKAGING SPECIFICATION (包裝作業規範)

SPEC.NO.(規範編號) Q9001SPP-1270T1

CONFIDENTIAL	TOP SECRET		
PAGE	2/4	REV.	A

PACKING OPERATION DIAGRAM & INSTRUCTION (包裝作業圖示及說明)

REMARK (備注)

Laying Product Diagram:  
(產品擺放圖示)

The side with 7 terminals faces "PVC-52"  
(端子数为7的一側朝向 "PVC-52")

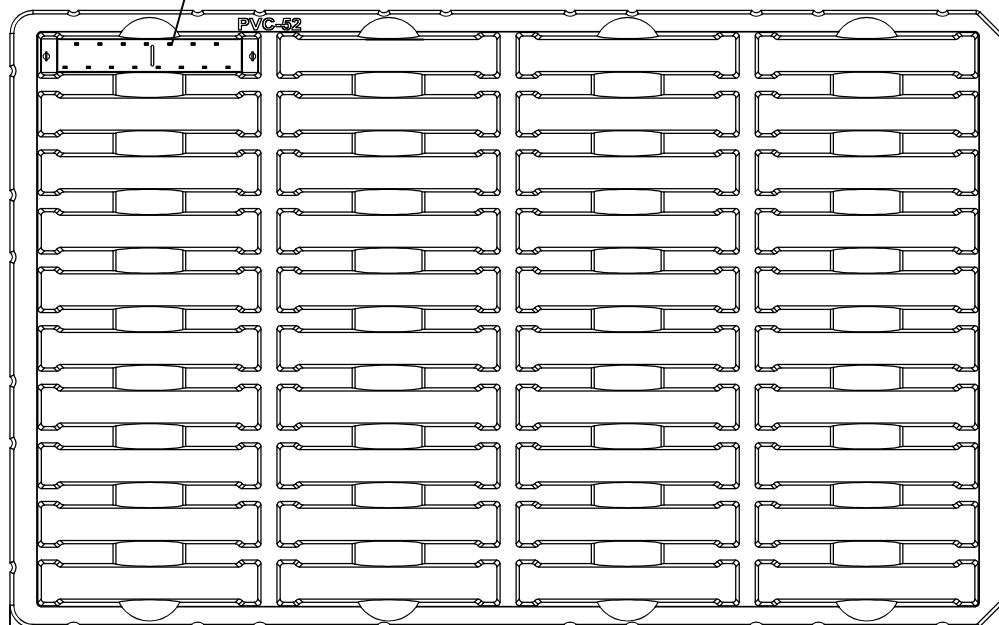

一.PVC Plate Packing Mode:  
(PVC盤包裝方式)

(1).CT-1.6 Box: PVC-52 17 PCS.

(CT-1.6 規格的紙箱放PVC-52盤 17 PCS)

(2).Put product in each trough fully as shown in diagram.  
(產品在盤子中擺放方式如圖所示)

(3).After filling each trough with product fully,cover it  
with transparent upper cover PVC-52-1 1PCS。  
(每盤放滿產品後,加蓋透明上蓋 PVC-52-1 1PCS)

(4).Stack the XX PVC plates filled with product, put them in  
the paper box in which has been put waterproof bag.  
(將放滿產品的XX個PVC盤疊起,裝入防水袋放入紙箱內)

# 歐品電子(昆山)有限公司

OUPIIN ELECTRONIC(KUNSHAN) CO.,LTD.

PACKAGING SPECIFICATION (包裝作業規範)

<input checked="" type="checkbox"/> CONFIDENTIAL <input type="checkbox"/> TOP SECRET	
PAGE	3/4
REV.	A

SPEC.NO.(規範編號) Q9001SPP-1270T1

## PACKING OPERATION DIAGRAM & INSTRUCTION (包裝作業圖示及說明)

## REMARK (備注)

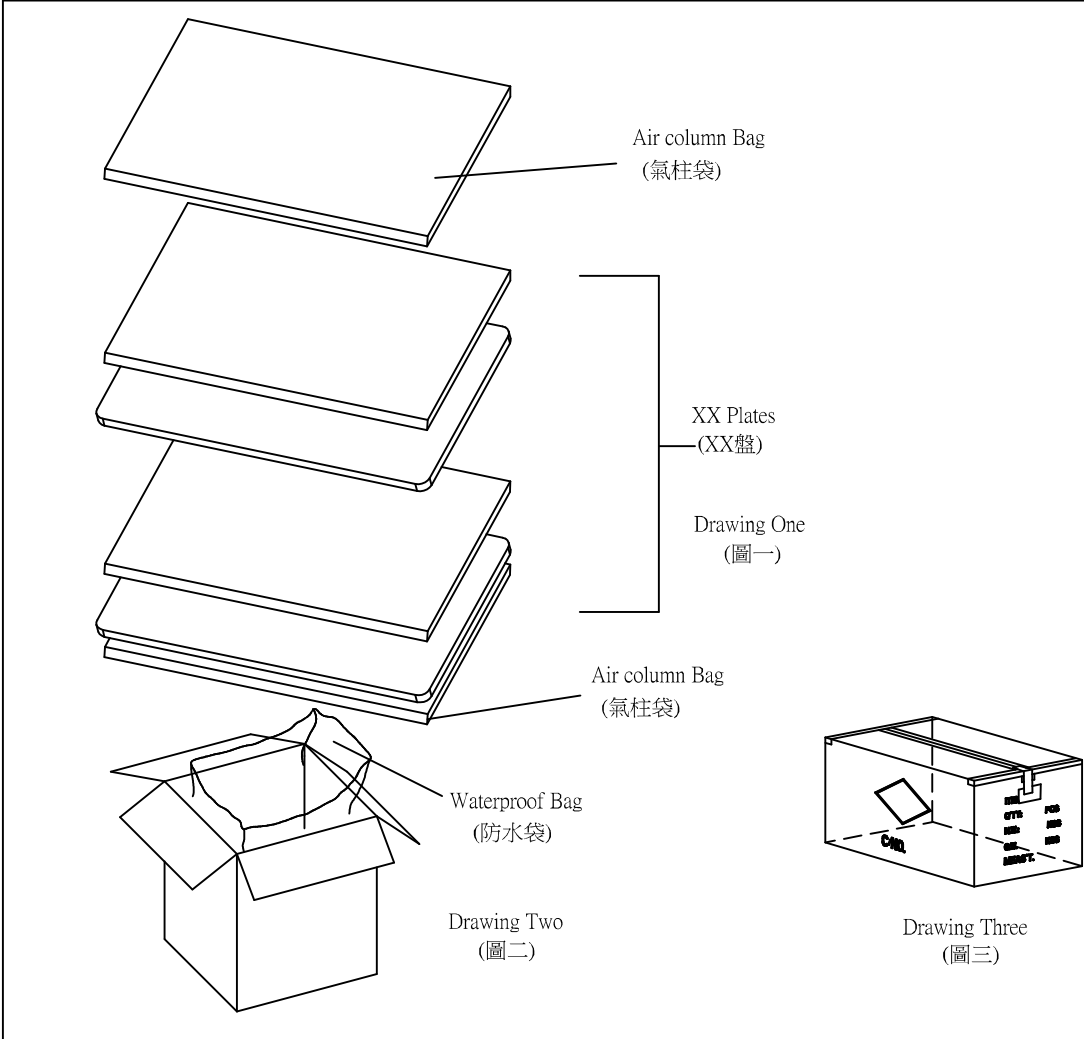

### 一. Outer Box Packing Mode: (外箱包裝方式)

- (1). Paper box 1.6 standard 1 PCS, as shown in drawing Two. (紙箱1.6規格 1 PCS. 如(圖二)所示)
- (2). Put one Air column bag in the upper and lower of the paper box, 2PCS in all, as shown in drawing One. (每箱上下各放一塊氣柱袋, 共2PCS, 如(圖一)所示)
- (3). Put 1 PCS waterproof in the paper box, as shown in drawing Two. (紙箱內側放入防水袋 1 PCS. 如(圖二)所示)
- (4). Piled the XX packing plates packed up in the waterproof. (將放滿產品的XX個PVC盤疊起, 裝入防水袋內)
- (5). Seal the waterproof bag, then put the Air column bag 1PCS on the bag. (Put 1 PCS Air column bag at the right and left side in the paper box if it is necessary.) (封上防水袋, 然後放上第二塊氣柱袋) (必要時, 在紙箱的左右兩側各放一塊氣柱袋)
- (6). Seal the surface of the outer box, as shown in drawing Three. (將外箱上層封口. 如(圖三)所示)

The form on the right and flank side of the box must be filled correctly and clearly, take actual testing weight as the standard of each box gross weight.

外箱之正麥和側麥所要填寫之項目要填寫正確, 清晰, 每箱之毛重應以實測重量為準.

