

歐品電子(昆山)有限公司

OUPIIN ELECTRONIC(KUNSHAN) CO.,LTD.

PACKAGING SPECIFICATION (包裝作業規範)

CONFIDENTIAL TOP SECRET

SPEC.NO.(規範編號)	Q9001SPP-271T1	APPLICABLE CUSTOMER (適用客戶)	ALL	APPLICABLE PRODUCT (適用產品)	9001-C12xx(1/2)Cxx(L1)A	PACKAGING CATEGORY (包裝方式)	TRAY PLATE PACKING
						PAGE	1/4
						REV.	K

REVISION HISTORY (修訂履歷)

ECN NO. REV.	PAGE (頁次)								
	1	2	3	4					
E	Newly-increased material number (修改料號)								
F	Revise the manner of packing (修改包裝方式)								
G	Revise the packaging quantity (修改包裝數量)								
H	Cancel upper cover change to empty chassis (取消上蓋變更為空底盤)								
J	Modification Plate Install Cover Explain (修改盤子包裝說明)								
K	New Material (新增料号)								

DIVISION (事業單位)	Product Development (產品開發課)	APPROVED (核准)	Peter Zhu	CHECKED (審核)	Nita Lu	PREPARED (制表)	Martin 03/21'23
-----------------	-----------------------------	---------------	-----------	--------------	---------	---------------	-----------------

歐品電子(昆山)有限公司

OUPIIN ELECTRONIC(KUNSHAN) CO.,LTD.

PACKAGING SPECIFICATION (包裝作業規範)

CONFIDENTIAL TOP SECRET

SPEC.NO.(規範編號) Q9001SPP-271T1

PAGE 2/4 REV. K

PACKING OPERATION DIAGRAM & INSTRUCTION (包裝作業圖示及說明)

REMARK (備注)

Laying Product Diagram:
(產品擺放圖示)



一.PVC Plate Packing Mode:
(PVC盤包裝方式)

(1).CT-1.6 Box: PVC-10 25 PCS.

(CT-1.6 規格的紙箱放PVC-10 25 PCS)

(2).Put product in each trough fully as shown in diagram.
(產品在盤子中擺放方式如圖所示)

(3).After each dish is filled with products,it is folded up
and the product is empty on the top of the mouth
(每盤放滿產品後疊起,最上面一層放空底盤)

(4).Stack the XX PVC plates filled with product, put them in
the paper box in which has been put waterproof bag.
(將放滿產品的XX個PVC盤疊起,裝入防水袋放入紙箱內)

歐品電子(昆山)有限公司

OUPIIN ELECTRONIC(KUNSHAN) CO.,LTD.

PACKAGING SPECIFICATION (包裝作業規範)

<input checked="" type="checkbox"/> CONFIDENTIAL <input type="checkbox"/> TOP SECRET	
PAGE	3/4
REV.	K

SPEC.NO.(規範編號) Q9001SPP-271T1

PACKING OPERATION DIAGRAM & INSTRUCTION (包裝作業圖示及說明)

REMARK (備注)

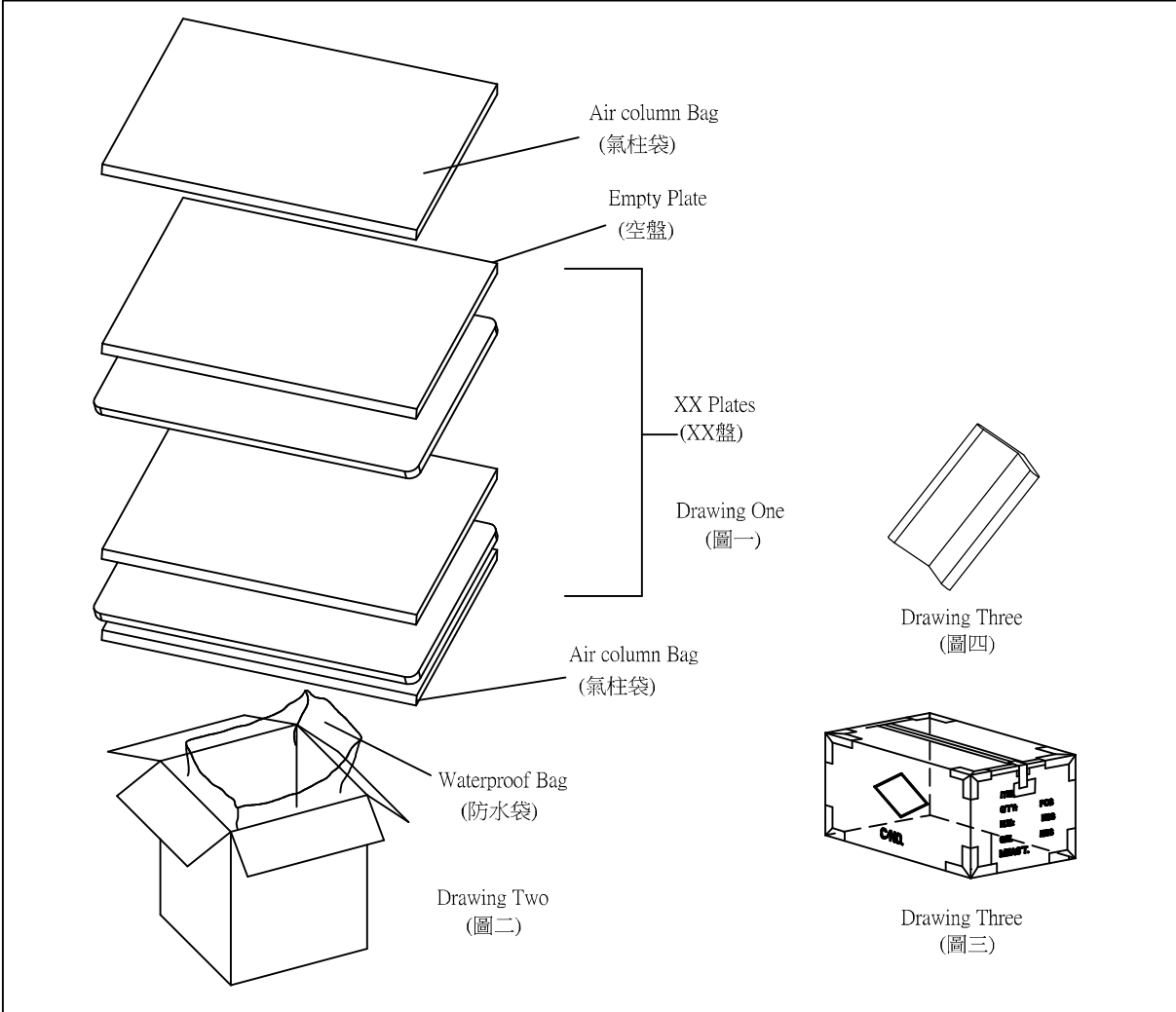

一. Outer Box Packing Mode: (外箱包裝方式)

- (1). Paper box 1.6 standard 1 PCS, as shown in drawing Two. (紙箱1.6規格 1 PCS, 如(圖二)所示)
- (2). Put one Air column bag in the upper and lower of the paper box, 2PCS in all, as shown in drawing One. (每箱上下各放一塊氣柱袋, 共2PCS, 如(圖一)所示)
- (3). Put 1 PCS waterproof in the paper box, as shown in drawing Two. (紙箱內側放入防水袋 1 PCS, 如(圖二)所示)
- (4). Piled the XX packing plates packed up in the waterproof. (將放滿產品的XX個PVC盤疊起, 裝入防水袋內)
- (5). Seal the waterproof bag, then put the Air column bag 1PCS on the bag. (Put 1 PCS Air column bag at the right and left side in the paper box if it is necessary.) (封上防水袋, 然後放上第二塊氣柱袋)
- (6). Seal the surface of the outer box, as shown in drawing Three. (將外箱上層封口, 如(圖三)所示)

(7) 4 sorrowful angles use the triangular support outside the carton, such as Fig. 4, every case packs the place with space to need by assuaring the Air column fill-ups, prevent rocking. 紙箱外側4個角使用三角支架, 如圖4, 每箱包裝有空隙的地方都需用氣柱袋填滿, 防止晃動。

The form on the right and flank side of the box must be filled correctly and clearly, take actual testing weight as the standard of each box gross weight.

外箱之正麥和側麥所要填寫之項目要填寫正確, 清晰, 每箱之毛重應以實測重量為準。

歐品電子(昆山)有限公司

OUPIIN ELECTRONIC(KUNSHAN) CO.,LTD.

PACKAGING SPECIFICATION (包裝作業規範)

CONFIDENTIAL TOP SECRET

SPEC.NO.(規範編號)		Q9001SPP-271T1					PAGE:		4/4	REV.	K
PACKING MATERIAL (包裝材料)			PRODUCT P/N	CT NO.	PACKING N.W.	PACKING QUANTITY (包裝數量)			WEIGHT (重量) kg		
MATERIAL NAME (材料名稱)	PART NO. (料號)	Q'TY	(產品料號)	(紙箱規格)	(包材重量)	PCS/TRAY	TRAY/BOX	PCS/BOX	N.W./PCS	N.W./BOX	G.W./BOX
PAPER BOXES (紙箱)	CT1.6	1	9001-C1232(1/2)CxxA	CT-1.6	3.97	40	25	1000	0.00983	9.83	13.80
Packing Box (包裝盒)	PVC-10	----	9001-C1232(1/2)CxxL1A	CT-1.6	3.97	40	25	1000	0.01013	10.13	14.10
WATERPROOF BAG (防水袋)	PE 100*90	1	9001-C1264(1/2)CxxA	CT-1.6	3.97	40	25	1000	0.01173	11.73	15.70
Triangular support (三角支架)	-----	4	9001-C1264(1/2)CxxL1A	CT-1.6	3.97	40	25	1000	0.01203	12.03	16.00
			9001-C1296(1/2)CxxA	CT-1.6	3.97	40	25	1000	0.01363	13.63	17.60
Air column bag (氣柱袋)	-----	2	9001-C1296(1/2)CxxL1A	CT-1.6	3.97	40	25	1000	0.01393	13.93	17.90
DRYING AGENT (干燥劑)	-----	3									

1.NOTE:

(注意):It is folded up and the product is empty on the top of the mouth (最上一層另外放一個空盤)

When the finished products have been made,take the actual weight as the standard of gross weight in each box.

(成品出貨時,每箱之毛重應以實測重量為準)

When the finished products have been made,stick the proper designation list on the box according to product demand.

(成品出貨時,依據出貨要求貼上相對應的標籤單)