

歐品電子(昆山)有限公司

OUPIIN ELECTRONIC(KUNSHAN) CO.,LTD.

PACKAGING SPECIFICATION (包裝作業規範)

SPEC.NO.(規範編號) Q9001SPP-238T1

<input checked="" type="checkbox"/> CONFIDENTIAL <input type="checkbox"/> TOP SECRET	
PAGE	2/4
REV.	F

PACKING OPERATION DIAGRAM & INSTRUCTION (包裝作業圖示及說明)

REMARK (備注)

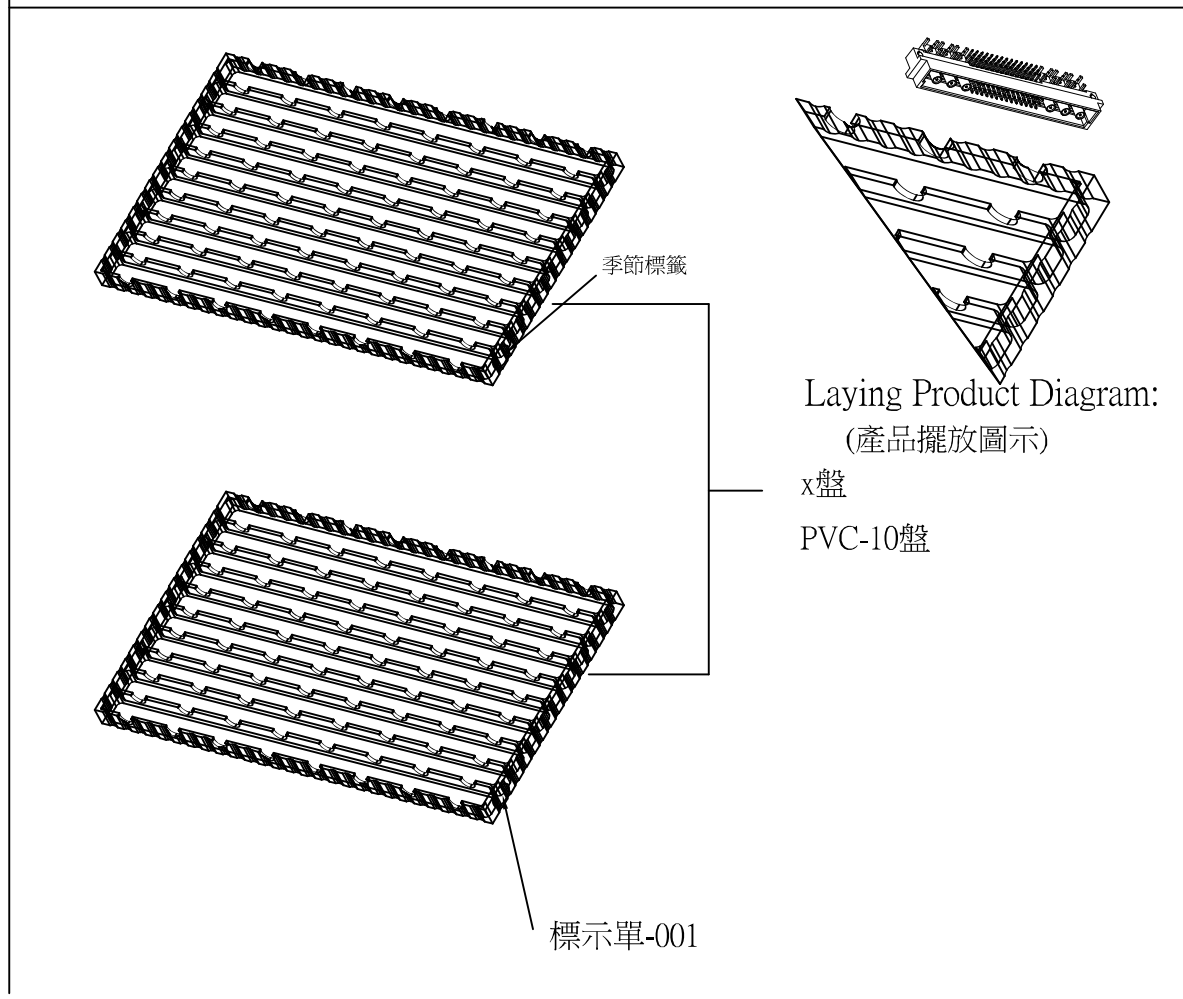

一.PVC Plate Packing Mode:
(PVC盤包裝方式):

(1).CT-1.6 Box: PVC-10 X PCS.

(CT-1.6 規格的紙箱放PVC-10盤 XPCS)

(2).Put product in each trough fully as shown in diagram.

The Dip must be up the products
(產品在盤子中擺放方式如圖所示)
(產品面針必須朝上)

(3).After filling each trough with product fully,paste the season label 1 PCS cover it with transparent upper cover PVC-073 1PCS。
(每盤放滿產品後,貼上季節標籤 1PCS,加蓋透明上蓋)
(PVC-073 1PCS)

(4).Stack the XX PVC plates filled with product, put them in the paper box in which has been put waterproof bag.
(將放滿產品的XX個PVC盤疊起,裝入防水袋放入紙箱內)

歐品電子(昆山)有限公司

OUPIIN ELECTRONIC(KUNSHAN) CO.,LTD.

PACKAGING SPECIFICATION (包裝作業規範)

<input checked="" type="checkbox"/> CONFIDENTIAL <input type="checkbox"/> TOP SECRET	
PAGE	3/4
REV.	F

SPEC.NO.(規範編號) Q9001SPP-238T1

PACKING OPERATION DIAGRAM & INSTRUCTION (包裝作業圖示及說明)	REMARK (備注)
---	-------------

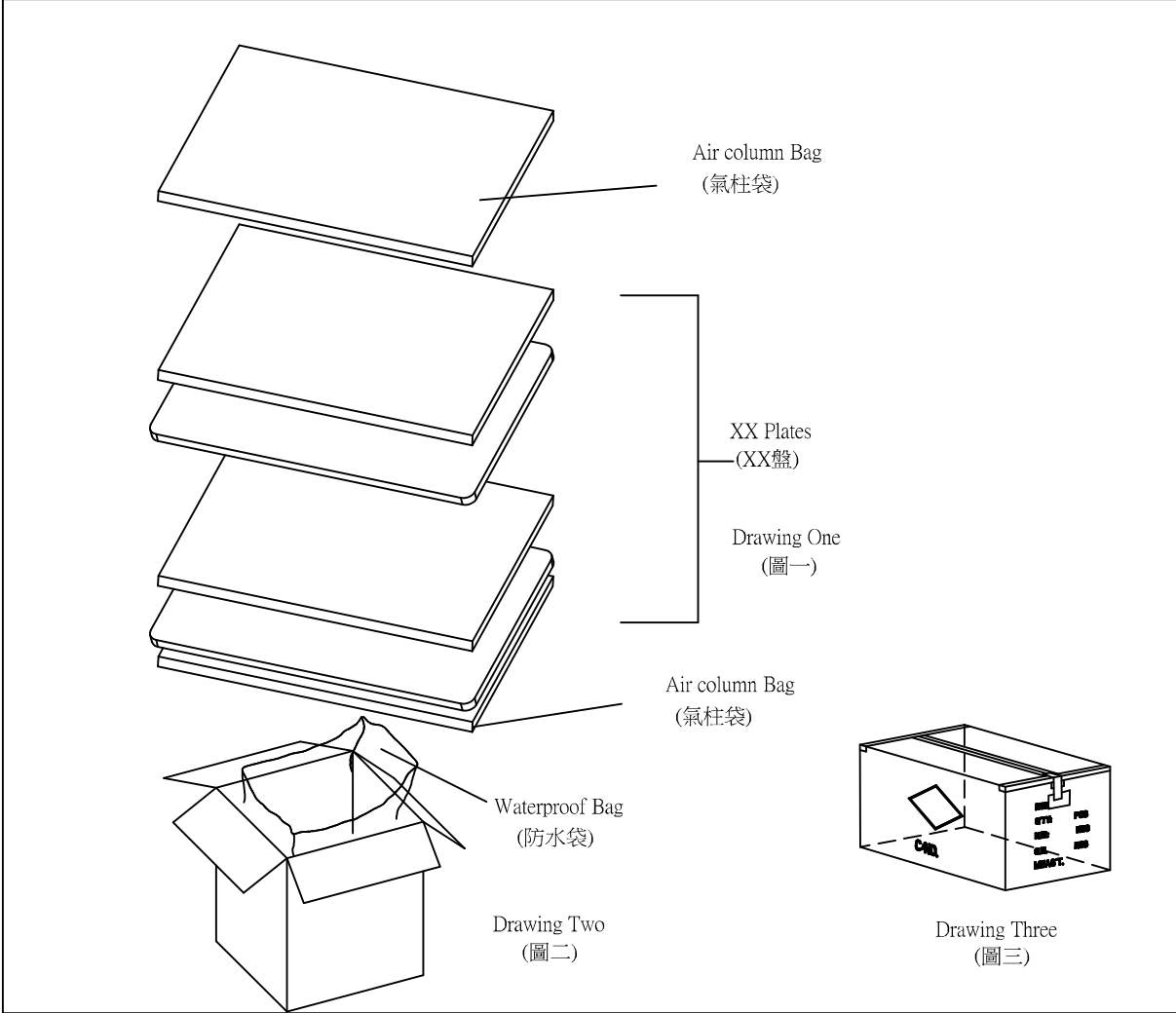

一. Outer Box Packing Mode:
(外箱包裝方式)

- (1). Paper box 1.6 standard 1 PCS, as shown in drawing Two.
(紙箱1.6規格 1 PCS, 如(圖二)所示)
- (2). Put one Air column bag in the upper and lower of the paper box, 2PCS in all, as shown in drawing One.
(每箱上下各放一塊氣柱袋, 共2PCS, 如(圖一)所示)
- (3). Put 1 PCS waterproof in the paper box, as shown in drawing Two.
(紙箱內側放入防水袋 1 PCS, 如(圖二)所示)
- (4). Piled the XX packing plates packed up in the waterproof.
(將放滿產品的XX個PVC盤疊起, 裝入防水袋內)
- (5). Seal the waterproof bag, then put the Air column bag 1PCS on the bag.
(Put 1 PCS Air column bag at the right and left side in the paper box if it is necessary.)
(封上防水袋, 然後放上第二塊氣柱袋)
(必要時, 在紙箱的左右兩側各放一塊氣柱袋)
- (6). Seal the surface of the outer box, as shown in drawing Three.
(將外箱上層封口, 如(圖三)所示)

The form on the right and flank side of the box must be filled correctly and clearly, take actual testing weight as the standard of each box gross weight.
外箱之正麥和側麥所要填寫之項目要填寫正確, 清晰, 每箱之毛重應以實測重量為準.

歐品電子(昆山)有限公司

OUPIIN ELECTRONIC(KUNSHAN) CO.,LTD.

PACKAGING SPECIFICATION (包裝作業規範)

CONFIDENTIAL TOP SECRET

SPEC.NO.(規範編號)		Q9001SPP-238T1										PAGE:	4/4	REV.	F
PACKING MATERIAL (包裝材料)			PRODUCT P/N	CT NO.	PACKING N.W.	PACKING QUANTITY (包裝數量)			WEIGHT (重量) kg						
MATERIAL NAME (材料名稱)	PART NO. (料號)	Q'TY	(產品料號)	(紙箱規格)	(包材重量)	PCS/TRAY	TRAY/BOX	PCS/BOX	N.W./PCS	N.W./BOX	G.W./BOX				
PAPER BOXES (紙箱)	CT1.6	1	9001-912408C00DA	CT-1.6	4.61	40	15	600	0.00765	4.59	9.20				
Packing Box (包裝盒)	PVC-10	----	9001-916004C00DA	CT-1.6	4.61	40	15	600	0.00782	4.69	9.30				
Packing Box Cover (包裝蓋子)	PVC-073	----													
WATERPROOF BAG (防水袋)	PE 100*70	1													
Air column bag (氣柱袋)	-----	2													
DRYING AGENT (干燥劑)	-----	3													

1.NOTE:

(注意):

When the finished products have been made,take the actual weight as the standard of gross weight in each box.

(成品出貨時,每箱之毛重應以實測重量為準)

When the finished products have been made,stick the proper designation list on the box according to product demand.

CT-1.6 Produce goods taiwan . (CT-1.6出貨台灣OP.)

It doesn't influence the manner of packing with the gold-plated way to print word way,Can amalgamate.(印字方式跟鍍金方式不影響包裝方式,可以共用)