

歐品電子(昆山)有限公司

OUPIIN ELECTRONIC(KUNSHAN) CO.,LTD.

PACKAGING SPECIFICATION (包裝作業規範)

CONFIDENTIAL TOP SECRET

SPEC.NO.(規範編號)	Q9392SPP-918				PAGE	1/4	REV.	A
APPLICABLE CUSTOMER (適用客戶)	ALL	APPLICABLE PRODUCT (適用產品)	9392-1P08N23CB30DA			PACKAGING CATEGORY (包裝方式)	TRAY PLATE PACKING	

REVISION HISTORY (修訂履歷)

ECN REV. NO	PAGE (頁次)									
	1	2	3	4						
A	NEW 新品发行									

DIVISION (事業單位)	Product Development (產品開發課)	APPROVED (核准)		CHECKED (審核)		PREPARED (制表)	WP 05/17'16
-----------------	-----------------------------	---------------	--	--------------	--	---------------	-------------

歐品電子(昆山)有限公司

OUPIIN ELECTRONIC(KUNSHAN) CO.,LTD.

PACKAGING SPECIFICATION (包裝作業規範)

■ CONFIDENTIAL		□ TOP SECRET	
PAGE	2/4	REV.	A

SPEC.NO.(規範編號) Q9392SPP-918

PACKING OPERATION DIAGRAM & INSTRUCTION (包裝作業圖示及說明)

REMARK (備注)

Laying Product Diagram: (產品擺放圖示)

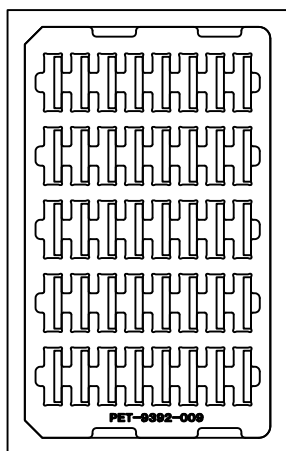

(Drawing 1-1)
(圖1-1)

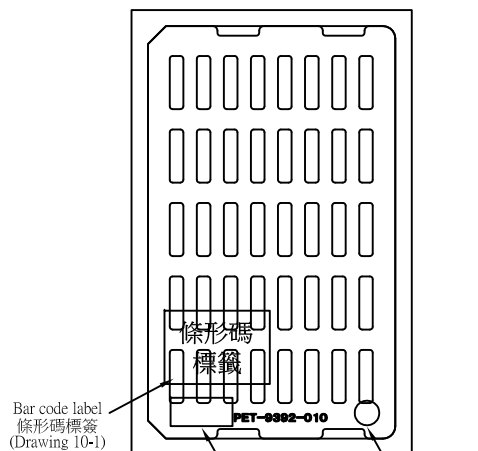







(Drawing 2)
(圖2)

Bar code label
條形碼標籤
(Drawing 10-1)
(圖10-1)

批次標籤

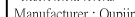
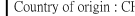
Season label
季節標籤

Customer P/N: xxxxxxxx

 Manufacturer P/N: 9392-1P08N23CB30DA

 QTY: xx PCS

 Vender Code:xxxxxx

 Lot No: xx-xx-xx

 Date No: xx-xx-xx

 Manufacturer: Oupiin Electronics

 Country of origin: CHINA

 DESC: 电源连接器

Label content of the bar code
條形碼標籤內容
(Drawing 10-1)
(圖10-1)

一. PET Plate Packing Mode: (PET盤包裝方式)

(1). CT-0.5 Box: PET-9392-009 xx PCS.
(CT-0.5規格的紙箱放PET-9392-009盤 xx PCS)

(2). Put product in each trough fully as shown in diagram. such as Fig1-1.
(產品在盤子中擺放方式如圖1-1所示)

(3). After filling each trough with product fully, cover it with transparent upper cover PET-9392-010 1PCS. the cover should be booked with the plate together, so as not to cause the products to fall scattered.

(每盤放滿產品後,加蓋透明上蓋 PET-9392-010 1PCS并在每個盤子上面加蓋子1PCS,蓋子要與底盤訂在一起,以免造成產品散落。)

(4) The label of minimum supplies label (the design of the supplies label is such as Fig. 2) and season is stuck separately on each cover (such as Fig. 2). Stick the label of bar code label (the design of the bar code label according to Fig. 10-1) **on each cover.**

在每個蓋子的上面分別貼批次標籤(樣式如圖2)與季節標籤(如圖2)。在每個蓋子的上面分別貼條形碼標籤(條形碼標籤的樣式如圖10-1)

(5). Stack the xx PET plates filled with product, put them in the paper box in which has been put waterproof bag.

(將放滿產品的xx個PET盤疊起,裝入防水袋放入紙箱內)

歐品電子(昆山)有限公司

OUPIIN ELECTRONIC(KUNSHAN) CO.,LTD.

PACKAGING SPECIFICATION (包裝作業規範)

<input checked="" type="checkbox"/> CONFIDENTIAL		<input type="checkbox"/> TOP SECRET	
PAGE	3/4	REV.	A

SPEC.NO.(規範編號) Q9392SPP-918

PACKING OPERATION DIAGRAM & INSTRUCTION (包裝作業圖示及說明)

REMARK (備注)

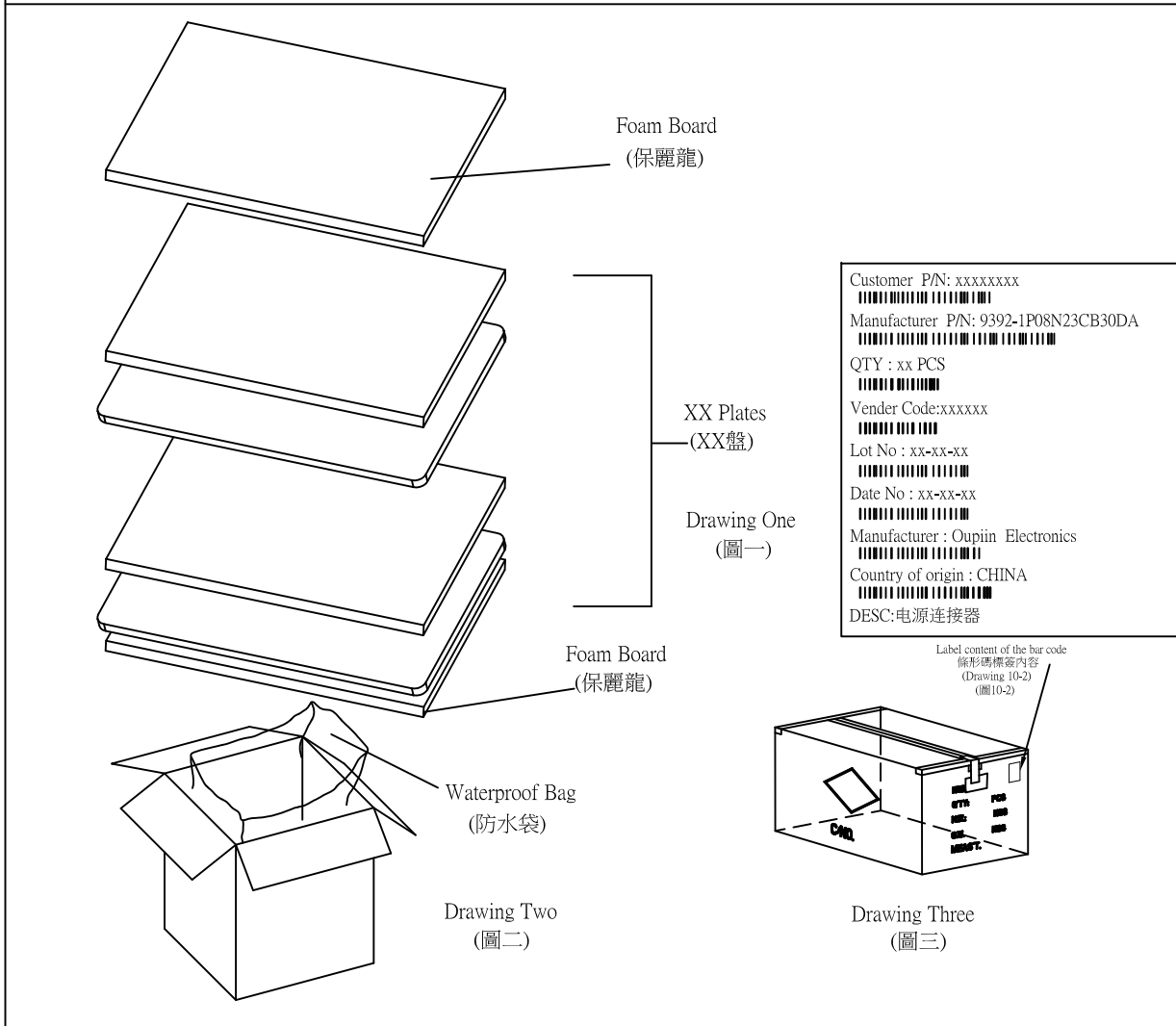

一. Outer Box Packing Mode:

(外箱包裝方式)

- (1). Paper box 0.5 standard 1 PCS, as shown in drawing Two.
(紙箱 0.5 規格 1 PCS, 如(圖二)所示)
- (2). Put one Foam Board in the upper and lower of the paper box, 2PCS in all, as shown in drawing One.
(每箱上下各放一塊保麗龍, 共2PCS, 如(圖一)所示)
- (3). Put 1 PCS waterproof in the paper box, as shown in drawing Two.
(紙箱內側放入防水袋 1 PCS, 如(圖二)所示)
- (4). Piled the XX packing plates packed up in the waterproof.
(將放滿產品的XX個PET盤疊起, 裝入防水袋內)
- (5). Seal the waterproof bag, then put the Foam Board 1PCS on the bag. if box can not be filled, filled with ploy.
(Put 1 PCS Foam Board at the right and left side in the paper box if it is necessary.)
封上防水袋後, 放上第二塊保麗龍薄板, 未填滿處用保麗龍填滿.
(必要時, 在紙箱的左右兩側各放一塊保麗龍)
- (6). Seal the surface of the outer box, as shown in drawing Three.
(將外箱上層封口, 如(圖三)所示)
- (7). Stick to the bar code label separately on case in each one! Bar code label design(Such as Fig. 10-2) can't write with hands
在每個外箱上(側邊)分別貼條形碼標籤(條形碼標籤的樣式(如圖10-2)不可用手寫)
- (8). The form on the right and flank side of the box must be filled correctly and clearly, take actual testing weight as the standard of each box gross weight.
外箱之正麥和側麥所要填寫之項目要填寫正確, 清晰, 每箱之毛重應以實測重量為準.

歐品電子(昆山)有限公司

OUPIIN ELECTRONIC(KUNSHAN) CO.,LTD.

PACKAGING SPECIFICATION (包裝作業規範)

CONFIDENTIAL TOP SECRET

PAGE: 4/4 REV. A

SPEC.NO.(規範編號) Q9392SPP-918

PACKING MATERIAL (包裝材料)			PRODUCT P/N	CT NO.	PACKING N.W.	PACKING QUANTITY (包裝數量)			WEIGHT (重量) kg		
MATERIAL NAME (材料名稱)	PART NO. (料號)	Q'TY	(產品料號)	(紙箱規格)	(包材重量)	PCS/TRAY	TRAY/BOX	PCS/BOX	N.W./PCS	N.W./BOX	G.W./BOX
PAPER BOXES (紙箱)	CT-0.5	1	9392-1P08N23CB30DA	CT-0.5	2.78	40	5	200	0.00837	1.67	4.45
Packing Box (包裝盒)	PET-9392-009	----									
Packing Box Cover (包裝盒蓋子)	PET-9392-010	----									
WATERPROOF BAG (防水袋)	PE 100*70	1									
Foam (保麗龍)	-----	2									
DRYING AGENT (干燥劑)	-----	3									

1.NOTE:
(注意)
When the finished products have been made,take the actual weight as the standard of gross weight in each box.(成品出貨時,每箱之毛重應以實測重量為準)
When the finished products have been made,stick the proper designation list on the box according to product demand.(成品出貨時,依據出貨要求貼上相對應的標籤單)
CT-1.6 Produce goods taiwan ,CT-1.9 Produce goods shanghai. (CT-1.6出貨台灣OP, CT-1.9出貨上海SH)
It doesn't influence the manner of packing with the gold-plated way to print word way,Can amalgamate.(印字方式跟鍍金方式不影響包裝方式,可以共用)

2.NOTE:
(注意)
*Pay attention to each big reel of material ,can be divided into 3 small reels,consumption of each big reel can't exceed 1meter, or the third reel can't be packed
(來料每大卷reel (carrier tape) 平均可分3小卷reel , 每大卷reel 消耗量不可超過1米,否則第三小卷不可包裝.)