

歐品電子(昆山)有限公司

OUPIIN ELECTRONIC(KUNSHAN) CO.,LTD.

PACKAGING SPECIFICATION (包裝作業規範)

CONFIDENTIAL TOP SECRET

SPEC.NO.(規範編號) Q9114SPP-766				PAGE	1/4	REV.	B
APPLICABLE CUSTOMER (適用客戶)	ALL	APPLICABLE PRODUCT (適用產品)	9114-C13ABS06CB30-CB30PPA			PACKAGING CATEGORY (包裝方式)	TRAY PLATE PACKING

REVISION HISTORY (修訂履歷)

ECN REV. NO	PAGE (頁次)								
	1	2	3	4					
A	INITIAL RELEASE (新版發行)								
B	APPLICABLE customers (修改适用客戶)								

DIVISION (事業單位)	Product Development (產品開發課)	APPROVED (核准)		CHECKED (審核)		PREPARED (制表)	LQ 07/26'16
-----------------	-----------------------------	---------------	--	--------------	--	---------------	-------------

歐品電子(昆山)有限公司

OUPIIN ELECTRONIC(KUNSHAN) CO.,LTD.

PACKAGING SPECIFICATION (包裝作業規範)

<input checked="" type="checkbox"/> CONFIDENTIAL <input type="checkbox"/> TOP SECRET	
PAGE	3/4
REV.	B

SPEC.NO.(規範編號) Q9114SPP-766

PACKING OPERATION DIAGRAM & INSTRUCTION (包裝作業圖示及說明)

REMARK (備注)

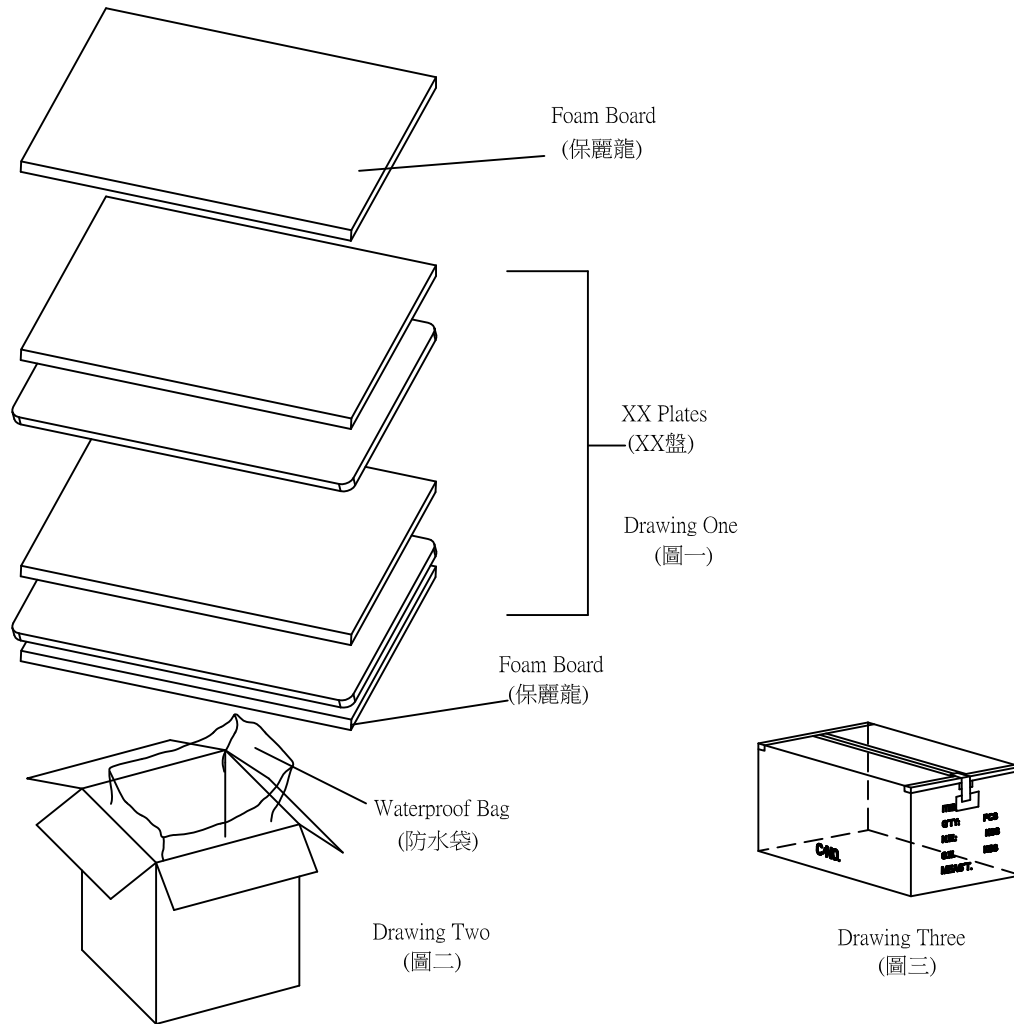

一. Outer Box Packing Mode:

(外箱包裝方式)

- (1). Paper box 0.9 standard 1 PCS, as shown in drawing Two.
(紙箱0.9規格 1 PCS, 如(圖二)所示)
- (2). Put one Foam Board in the upper and lower of the paper box, 2PCS in all, as shown in drawing One.
(每箱上下各放一塊保麗龍, 共2PCS, 如(圖一)所示)
- (3). Put 1 PCS waterproof in the paper box, as shown in drawing Two.
(紙箱內側放入防水袋 1 PCS, 如(圖二)所示)
- (4). Piled the XX packing plates packed up in the waterproof.
(將放滿產品的XX個PET盤疊起, 裝入防水袋內)
- (5). Seal the waterproof bag, then put the Foam Board XXPCS on the bag.
(Put 1 PCS Foam Board at the right and left side in the paper box if it is necessary.)
(封上防水袋, 然後放上第二塊保麗龍薄板)
(必要時, 在紙箱的左右兩側各放一塊保麗龍)
- (6). Seal the surface of the outer box, as shown in drawing Three.
(將外箱上層封口, 如(圖三)所示)

The form on the right and flank side of the box must be filled correctly and clearly, take actual testing weight as the standard of each box gross weight.

外箱之正麥和側麥所要填寫之項目要填寫正確, 清晰, 每箱之毛重應以實測重量為準。

歐品電子(昆山)有限公司

OUPIIN ELECTRONIC(KUNSHAN) CO.,LTD.

PACKAGING SPECIFICATION (包裝作業規範)

<input checked="" type="checkbox"/> CONFIDENTIAL		<input type="checkbox"/> TOP SECRET	
PAGE:	4/4	REV.	B

SPEC.NO.(規範編號)		Q9114SPP-766									
PACKING MATERIAL (包裝材料)			PRODUCT P/N	CT NO.	PACKING N.W.	PACKING QUANTITY (包裝數量)			WEIGHT (重量) kg		
MATERIAL NAME (材料名稱)	PART NO. (料號)	Q'TY	(產品料號)	(紙箱規格)	(包材重量)	PCS/TRAY	TRAY/BOX	PCS/BOX	N.W./PCS	N.W./BOX	G.W./BOX
PAPER BOXES (紙箱)	CT-0.9	1	9114-C13ABS06CB30-CB30PPA	CT-0.9	2.63	91	6	546	0.006160	3.36	5.99
Packing Box (包裝盒)	PVC-9114-017	6									
Packing Box Cover (包裝盒蓋子)	PVC-9114-018	6									
WATERPROOF BAG (防水袋)	PE 100*70	1									
Foam (保麗龍)	-----	----									
DRYING AGENT (干燥劑)	-----	----									

1.NOTE:

(注意)

When the finished products have been made,take the actual weight as the standard of gross weight in each box.

(成品出貨時,每箱之毛重應以實測重量為準)

When the finished products have been made,stick the proper designation list on the box according to product de

CT-1.6 Produce goods taiwan , CT-1.9 Produce goods shanghai. (CT-1.6出貨台灣OP , CT-1.9出貨上海SH)

It doesn't influence the manner of packing with the gold-plated way to print word way.Can amalgamate.(印字方式跟鍍金方式不影響包裝方式,可以共用)