



# PRODUCT SPECIFICATION

## (產品規格書)

產品名稱 Description	產品料號 Part No.	圖號 Drawing No.
High Speed Connector 0.8mm(0.0315")Pitch SMD Type	2386-22XxxCxDxLT-x	2386-D0000-00x
	2386-32XxxCxDxLT-x	2386-D0000-00x

PRODUCT NAME (產品名稱)	DOCUMENT No.: (文件編號)	Rev. (版本)	OUPIIN
High Speed Connector 0.8mm(0.0315")Pitch SMD Type (RoHS)	Q2386-PSS-002	A (I800)	(歐品)
	Approved (核准)	Checked (審核)	Prepared (製作)
	Q.A. Section Chief	Ruru Chen	2022.03.23



# PRODUCT SPECIFICATION OF OUPIIN

## 1. SCOPE 範圍

This product specification defines the product performance and the test methods to ascertain the performance of the High Speed Connector 0.8mm(0.0315")Pitch SMD Type, which is designed and manufactured by Oupiin Electronic Co.,Ltd. This product specification is applicable but not only for those part numbers which be shown in the cover page.

本產品規格書規定了由歐品電子有限公司生產的 High Speed Connector 0.8mm(0.0315")Pitch SMD 型連接器,產品的特性及測試方法。本產品規格書適用於但不局限於封面所顯示的產品料號。

## 2. REFERENCE DOCUMENTS 參考文件

MIL-STD-1344	Test method for electrical connector 電子連接器測試方法
MIL-STD-202	Test method for electrical components 電子零件測試方法
EIA364	Test method for electrical components 電子零件測試方法
JIS C 0051	Test method for electrical components 電子零件測試方法
MIL-G-45204C	Specification for gold plating 鍍金規格
IEC-512-3	IEC standard for current carrying capacity tests IEC 電流測試標準
QQ-N-290A	Specification for nickel plating 鍍鎳規格
MIL-P-81728A	Specification for tin/lead plating 鍍錫鉛規格
MIL-T-10727B	Specification for tin plating 鍍錫規格
UL1977	UL standard for safety of attachment plug and receptacle UL 安規要求標準

## 3. FEATURE & DIMENSIONS 特徵及尺寸

### 3.1. PRODUCT DIMENSION 產品尺寸

These connectors shall have the dimensions as shown in drawing.

本產品的相關尺寸參考圖面。

### 3.2. MALE AND FEMALE PRODUCT 公母產品裝配

#### 3.2.1.Male and Female assembly dimension 公母產品裝配尺寸

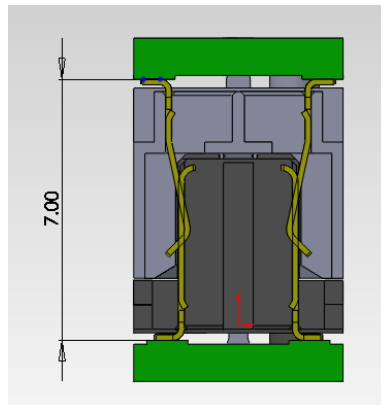

Distance between male's PCB and female's PCB is 7.00REF

公母 PCB 板之間的尺寸為 7.00REF

3.2.2 Perpendicular to engaging direction 垂直插入方向

The design of the centering and guiding in the Mpc of the free and fixed board connector modules shall accept a misalignment of 1.50mm in transverse and 1.50mm in longitudinal axes of the connector

固定板連接器模件的Mpc裡，連接器設計中心線橫向可接受1.50mm和縱向可接受1.50mm的偏差。

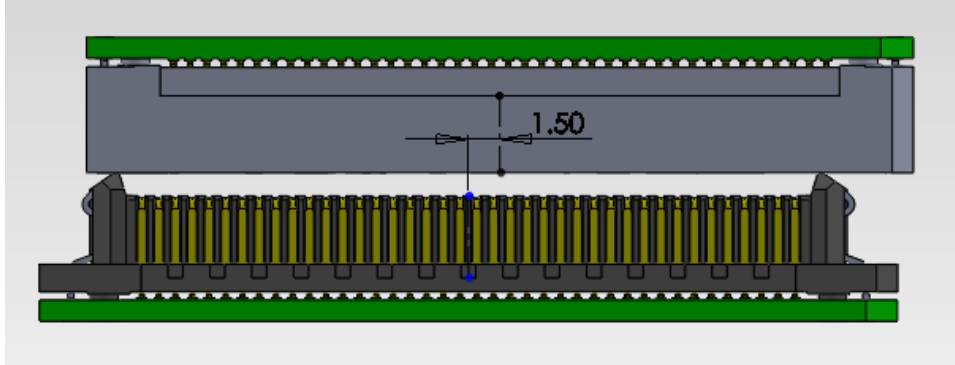

allowed misalignment in transverse axes 在橫向方向允許對插偏差量

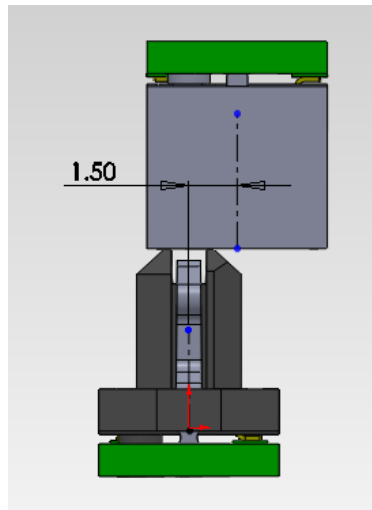

allowed misalignment in longitudinal axes 在縱向方向允許對插偏差量

3.2.3 Inclination 傾向

The center and guiding in the Mpc of the free and the fixed board connector modules shall allow an initial angular misalignment of 2 from both the transverse and longitudinal axes

固定板連接器模件的在Mpc裡，連接器可接受橫向和縱向2° 的最大傾斜對插角度。

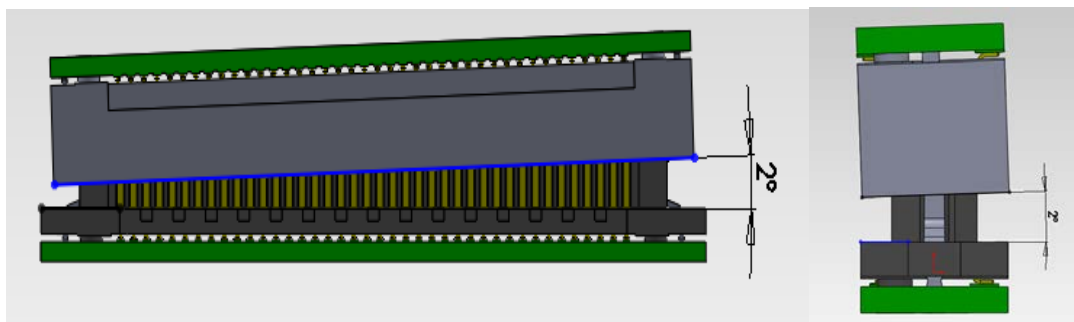



## PRODUCT SPECIFICATION OF OUPIIN

### 3.3. PCB/PANEL LAYOUT 印刷電路板佈局

The recommended PCB layout is shown in drawing.

本產品適用的 PCB layout 參考圖面。

### 3.4. BILL OF MATERIAL 材料清單

Harmful material control follow the requirement of RoHS. The bill of material and product number is described in drawing.

有害物質控制符合RoHS指令要求.本產品使用的材料參見圖面。

### 3.5. MECHANICAL & ELECTRICAL CHARACTERISTIC 機械及電氣特性

The connector shall have the mechanical and electrical performance as described in drawing.

本產品的機械及電氣特性見圖面

### 3.6. PACKAGING 包裝

Products shall be packaged according to requirements specified in purchase order for safe delivery, connector container and the packaging method are shown in package specification.

產品可依客戶指定要求包裝，包裝材料與包裝方式參見產品包裝規範

### 3.7. RATING CURRENT AND RATING VOLTAGE 額定電流與額定電壓

Rating current is 1.5 A Per Contact With 1 Contact , rating voltage is 300 VAC .

額定電流 1.5A 每PIN(串聯1PIN測試)，額定電壓300 VAC

### 3.8. OPERATING TEMPERATURE 儲存與使用溫度

Temperature range: -55°C~+125°C, including terminal temperature rise for rating current.

溫度範圍：-55°C~+125°C，包含接觸端子的額定電流溫升

## 4. ENVIRONMENTAL 環境要求

### 4.1. SOLDERABILITY 可焊性

Connectors meet solder-ability to EIA-364-52.and shall be free of contaminants.

產品可焊性符合 EIA-364-52. 標準規定的相關要求，表面不得有污染物。

### 4.2. RESISTANCE TO SOLDER HEAT 耐焊接熱

#### 4.2.1. INFRARED REFLOW 紅外線回流焊接

Each cycle consists of three consecutive phases, as shown in Table III.

每個焊接週期包括三個連續的階段，見附表三



# PRODUCT SPECIFICATION OF OUPIIN

Note: 說明

Device temperature measurements are referenced from the top-center of the package outer surface.  
設備溫度量測時以從頂部中間位置測量為準。

## 5. PERFORMANCE AND TEST DESCRIPTION 性能及測試

### 5.1. REQUIREMENT 要求

Product is designed to meet electrical, mechanical, and environmental performance requirements specified in Table I.

本產品設計符合附表一所述的機械，電氣及環境要求。

### 5.2. TEST CONDITION 測試條件

Unless otherwise specified, all tests shall be performed at ambient environmental conditions.

除非特別註明，所有測試在室溫條件下完成。

### 5.3. SAMPLE SELECTION 樣品選擇

Test samples shall be selected at random from current production. No test samples shall be reused.

Samples are pre-conditioned with 10cycles of durability. Each group shall be containing 5 test samples.

測試樣品從現生產的產品中隨機抽取，所有測試過的樣品不得重複使用。樣品已預先插拔10次，每組測試有5個樣品。

### 5.4. TEST SEQUENCE 測試順序

Product qualification test sequence as shown in Table II.

產品品質測試順序見附表二



## PRODUCT SPECIFICATION OF OUPIIN

### Table I: Test Requirements and Procedures

#### 附表一: 測試要求與方法

Items (項目)	Requirements (要求)	Test Methods (檢測方法)
1. Confirmation of Product (產品確認)	Product shall be conforming to the requirements of applicable product drawing. 產品必須滿足相關檔的規定	Visually, dimensions and functionally inspected per applicable product drawing. 依相關產品圖面，檢查產品的外觀、尺寸及功能。
2. Contact Resistance (接觸阻抗)	25 mΩ Max. initial. 初始狀態最大 25 mΩ	Subject mated contacts assembled in housing to closed circuit of 100 mA max. 20 mV max. Per EIA-364-06 所述固定在外殼裡的端子連結到一個封閉回路中測試，電流 100 mA max，電壓 20 mV max。 適用：EIA-364-06
3. Insulation Resistance (絕緣阻抗)	50000 MΩ Min. 最小 50000 MΩ	Measure by applying test potential between the adjacent contacts, and between the contacts and ground in the mated connector. (500 V DC±10%). Per EIA-364-21 (500 V DC±10%). 測試產品相鄰端子間以及端子與接地間的電阻，(500 V DC±10%)。適用：EIA-364-21
4. Dielectric Withstanding Voltage (耐電壓)	Connector must withstand test potential of 500 VAC RMS for 1 minute, current leakage must be 0.5mA Max. 產品必須承受測試電壓 500 VAC RMS，時間 1 分鐘，漏電流不大於 0.5 mA。	Measure by applying test potential between the adjacent contacts, and between the contacts and ground in the mated connector. Per EIA-364-20 對產品相鄰端子間以及端子與接地間加載電壓，並測試其漏電流。適用：EIA-364-20.
5. Durability (Repeated Mating/Unmated) (耐久性)	After testing : Maximum Change: Contact Resistance: 15 mΩ 測試後，接觸阻抗最大變化 15mΩ	Repeat mate and unmated for connector 500 cycles, at a speed of 25.4 mm per minute. Per EIA-364-09 重復進行配合產品 500 次插拔，速度 25.4mm/分鐘。 適用：EIA-364-09



## PRODUCT SPECIFICATION OF OUPIIN

<p>6. Mating/Un-mating Force (插入力/拔出力)</p>	<p>Mating force: 0.60N/Pair Pin Max. Un-mating force: 0.1N/ Pair Pin Min. 每對插入力最大 0.60N， 每對拔出力最小 0.1N。</p>	<p>At a speed of 25.4±3 mm/minute, apply axial insert the mating part into fully or pull out from the subject product. Per EIA-364-09 以 25.4±3 mm/分鐘的速度，軸向完全插入對配外掛程式到被測產品中或從被測產品中拔出。 適用：EIA-364-09</p>
<p>7. Contact Retention Force (端子保持力)</p>	<p>Male pin: 0.1kgf /Pin. Min. Female pin: 0.1kgf /Pin. Min. Male pin 每支最小 0.1kgf Female pin 每支最小 0.1kgf</p>	<p>Apply axial pull out force at a speed of 25.4±3 mm/minute on the contact assembled in the housing. Per EIA-364-29 以 25.4±3 mm/分鐘的速度施加軸向拉力從塑膠本體上拔出端子。適用：EIA-364-29</p>
<p>8. Normal Forec-Initial (正向力)</p>	<p>0.30 N/Pin.Min 每支最小 0.30 N</p>	<p>Exert the axial pressure from carrying the plastics under the sub radian highest point at the speed of 25±3 mm/minute. Per EIA-364-04 以 25±3 mm/分鐘的速度施加軸向壓力從端子弧度最高處下壓到塑膠面。適用：EIA-364-04</p>
<p>9. Vibration (機械振動)</p>	<p>After testing, no damage. No electrical discontinuity greater than 1µs shall occur. Contact Resistance: Maximum Change: Contact: 15 mΩ 測試後，產品無損壞，不允許出現超過 1µs 的瞬間斷開，接觸阻抗 PIN 最大變化 15 mΩ</p>	<p>Subject mated connector to 50-2000-50 Hz traversed in 1 minute at 1.5 mm amplitude, 2 hours each of 3 mutually perpendicular plane , 10 mA potential applied. Per EIA-364-28. 對測試產品，在頻率變化每分鐘從 50-2000-50 Hz，振幅 1.5 mm 條件下，在互相垂直的三個面上，每個面 2 小時下測量，電流 10 mA 適用：EIA-364-28</p>
<p>10. Thermal Shock (溫度沖擊)</p>	<p>After testing, no damage, Contact Resistance: Maximum Change: Contact: 15 mΩ. Dielectric Strength should be OK, Insulation Resistance should be 5000 MΩ Min. 測試後，產品無損壞，接觸阻抗 PIN 最大變化 15mΩ；耐電壓測試 OK，絕緣阻抗最小 5000 MΩ</p>	<p>Temperature range from -55°C to+85°C. Start from -55°C, after 30 minutes, change to +85°C change time is no more than 5 minute, total 5 cycles. Per EIA-364-32 溫度變化範圍：-55°C~ +85°C。從 -55°C 開始，30 分鐘後換到+85°C，轉換時間不超過 5 分鐘，共 5 個循環。適用：EIA-364-32</p>



## PRODUCT SPECIFICATION OF OUPIIN

<p>11. Humidity-Temperature Cycle (溫濕度循環)</p>	<p>After testing, no damage, Contact Resistance: Maximum Change: Contact: 15 mΩ. Dielectric Strength should be OK, Insulation Resistance should be 5000 MΩ Min. 測試後，產品無損壞，接觸阻抗 PIN 最大變化 15mΩ；耐電壓測試 OK，絕緣阻抗最小 5000 MΩ</p>	<p>Subject product to 25~65°C, 90-95%.R.H, Duration:240 Hours. Per EIA-364-31 產品置於 25~65°C，相對濕度：90-95%，持續時間:240 小時。 適用：EIA-364-31</p>
<p>12. Salt Spray (鹽霧)</p>	<p>After testing, no damage, Contact Resistance: Maximum Change: Contact: 15 mΩ. Dielectric Strength should be OK, Insulation Resistance should be 5000 MΩ Min. 測試後，產品無損壞，接觸阻抗 PIN 最大變化 15mΩ；耐電壓測試 OK，絕緣阻抗最小 5000 MΩ</p>	<p>5±1% salt concentration(PH=7.0) ,48 hours , 35±2°C. Per EIA-364-26. 鹽水濃度 5±1%(PH=7.0)，時間 48 小時，溫度 35±2°C 適用：EIA-364-26</p>
<p>13. High Temperature Life (高溫老化)</p>	<p>After testing, no damage, Contact Resistance: Maximum Change: Contact: 15 mΩ. Dielectric Strength should be OK, Insulation Resistance should be 5000 MΩ Min. 測試後，產品無損壞，接觸阻抗 PIN 最大變化 15mΩ；耐電壓測試 OK，絕緣阻抗最小 5000 MΩ</p>	<p>Subject product to 105±3°C for 250 hours continuously. EIA-364-17 產品置於 105±3°C，連續 250 小時。 適用：EIA-364-17</p>
<p>14. Solder ability (可焊性)</p>	<p>Appearance of the specimen shall be inspected after the test with the assistance of a magnifier capable of giving a magnification of 10 X for any damage such as pinholes, void or rough surface.5% maximum dewetting. 產品在測試完成後，在放大倍數為 10 倍的顯微鏡下，檢查外觀損壞如：小孔，空焊，外觀粗糙度。未沾錫區不大於 5%</p>	<p>Soldering time: 5 seconds. Temperature: 245±5°C. Per EIA-364-52 焊接時間：5 秒 溫度：245±5°C 適用：EIA-364-52</p>
<p>15. Impedance (single-ended) (單線特性阻抗)</p>	<p>50 ± 10% ohms 50± 10% 歐姆</p>	<p>Mate connectors: rise time of 1 ns 配對組連接器：1 ns 的上升時間</p>
<p>16. Impedance (differential pair) (差分特性阻抗)</p>	<p>100 ± 10% ohms 100± 10% 歐姆</p>	<p>Mate connectors: rise time of 150 ps。 配對組連接器：150 ps 的上升時間</p>





## PRODUCT SPECIFICATION OF OUPIIN

17. Differential Insertion Loss (differential pair) (差分插損)	Average: 13 GHz 平均：13 GHz	Mate connectors: -3db 配對組連接器：-3db
18. Differential Insertion Loss (single-ended) (單線插損)	Average: 12GHz 平均：12GHz	Mate connectors: -3db 配對組連接器：-3db



PRODUCT SPECIFICATION OF OUPIIN

**Table II: Product Qualification Test Sequence**

附表二：產品測試順序

Test Description 測試描述	Test Group 測試分組								
	A	B	C	D	E	F	G	H	J
1. Conformation of Product 產品確認	1,7	1,4	1,3	1,9	1,9	1,9	1,9	1,9	1,3
2. Contact Resistance 接觸阻抗	2,6			2,6	2,6	2,6	2,6	2,6	
3. Insulation Resistance 絕緣阻抗	3			3,7	3,7	3,7	3,7	3,7	
4. Dielectric Withstanding Voltage 耐電壓	4			4,8	4,8	4,8	4,8	4,8	
5. Durability(Repeated Mating/Un-mating) 耐久性	5								
6. Mating/Un-mating Force 插入/拔出力		2							
7. Contact Retention Force 端子保持力		3							
8. Normal Forec-Initial 正向力			2						
9. Vibration 機械振動				5					
10. Thermal Shock 溫度沖擊					5				
11. Humidity-Temperature Cycle 溫濕度循環						5			
12. Salt Spray 鹽霧							5		
13. .High Temperature Life 高溫老化								5	
14. Solder-ability 可焊性									2

**Table III: Reflow Soldering Profile**

附表三：回流焊接曲線圖

Lead-free reflow profile requirements:

無鉛回流焊接曲線

Parameter 參數	Reference 參考	Specification 規格
升溫區 Ramp-up	25°C ~150°C	3°C /S Max
預熱區(Pre-heating) Temperature Min( $T_{smin}$ ) Temperature Max( $T_{smax}$ ) Time( $T_{smin}$ to $t_{smax}$ )	150°C ~200°C	60~180sec
Time maintained above(保持時間) Temperature( $T_L$ ) Time( $t_L$ )	217°C	60~150sec
Time within 5°C of actual peak Temperature( $t_p$ )	260-/+5°C	20~40sec
冷卻區 Cooling	Ramp-Down Rate	6°C /S(Max)
Time 25°C to Peak Temperature	25°C ~ Peak Temp.	8 minutes maximum

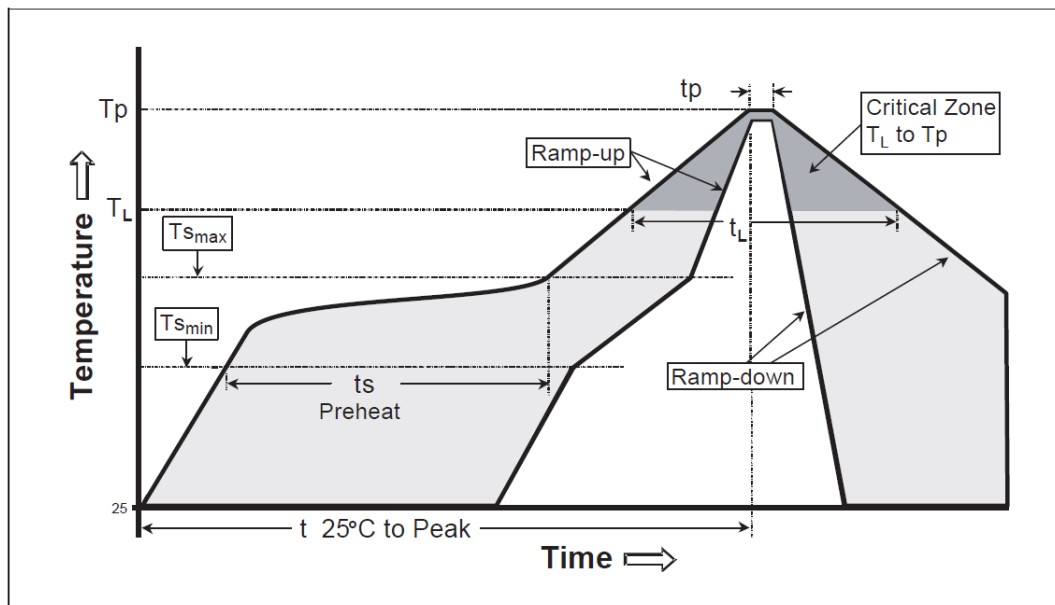

This profile is the minimum requirement for evaluating soldering heat resistance of components .Heat transfer method used for reflow soldering is hot air convection .The actual air temperatures used to achieve the specified profile largely dependent on the reflow equipment.

這個曲線圖是評估元件器件焊接抗熱的基本要求。應用在對焊接中的熱傳遞方式是熱氣對流。達到特定曲線圖地實際溫度主要依賴與回流焊接設備。