

## Part List

Connector	SlimSAS 8i STR Plug.
SAS Cable	Twin-AX Single Pair, UL.
Label	Synthetic Paper, W40.0mm, White
Acetate Tape	Black.
Expando Tube	Black.

**NOTE:**

- 1.The Cable Assembly Shall Be RoHS2.0 Compliant.
- 2.The Cable Assembly Shall Meet Below Impedance Require Ment:  
Termination Area:(85 or 100) ±15% Ohms.  
Cable Absolute Area:(85 or 100)±10% Ohms.
- 3.Electrical Mechanical Performance Shall Be Meet SAS4.0 Specification.

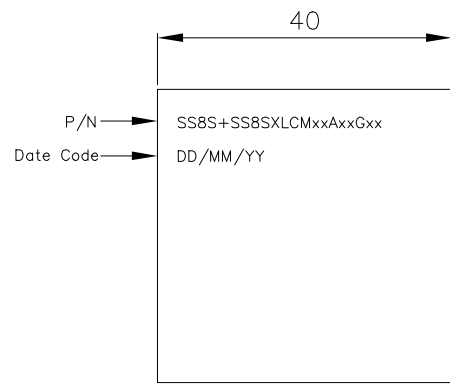
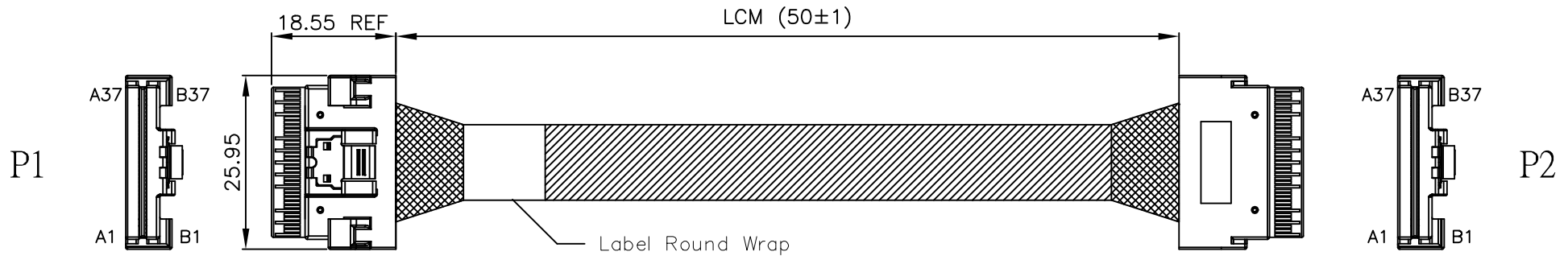

LABEL DETAIL

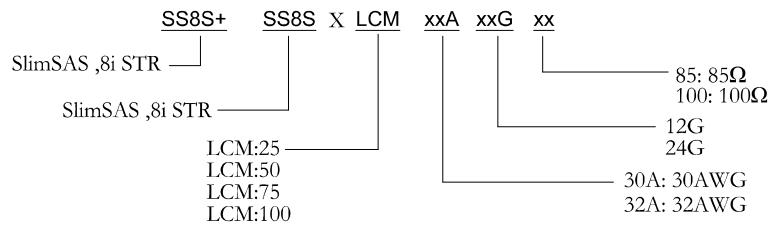

Tolerances	Dwg. No.	S0220220309-01	Part No.	<b>OUPIIN</b> OUPIIN ENTERPRISE CO., LTD.			
.x = ±0.50	Projection	⊕ ↙	SS8S+SS8SXLCMxxAxxGxx				
.xx = ±0.30	Unit <i>mm</i>	Scale	Title:	SHEET	1/2	Ver.No.	X1
.xxx = ±0.15	Drawn By	Martin 03/09'22	Slim SAS 8i STR to SlimSAS 8i STR Cable ①517				

# WIRING TABLE

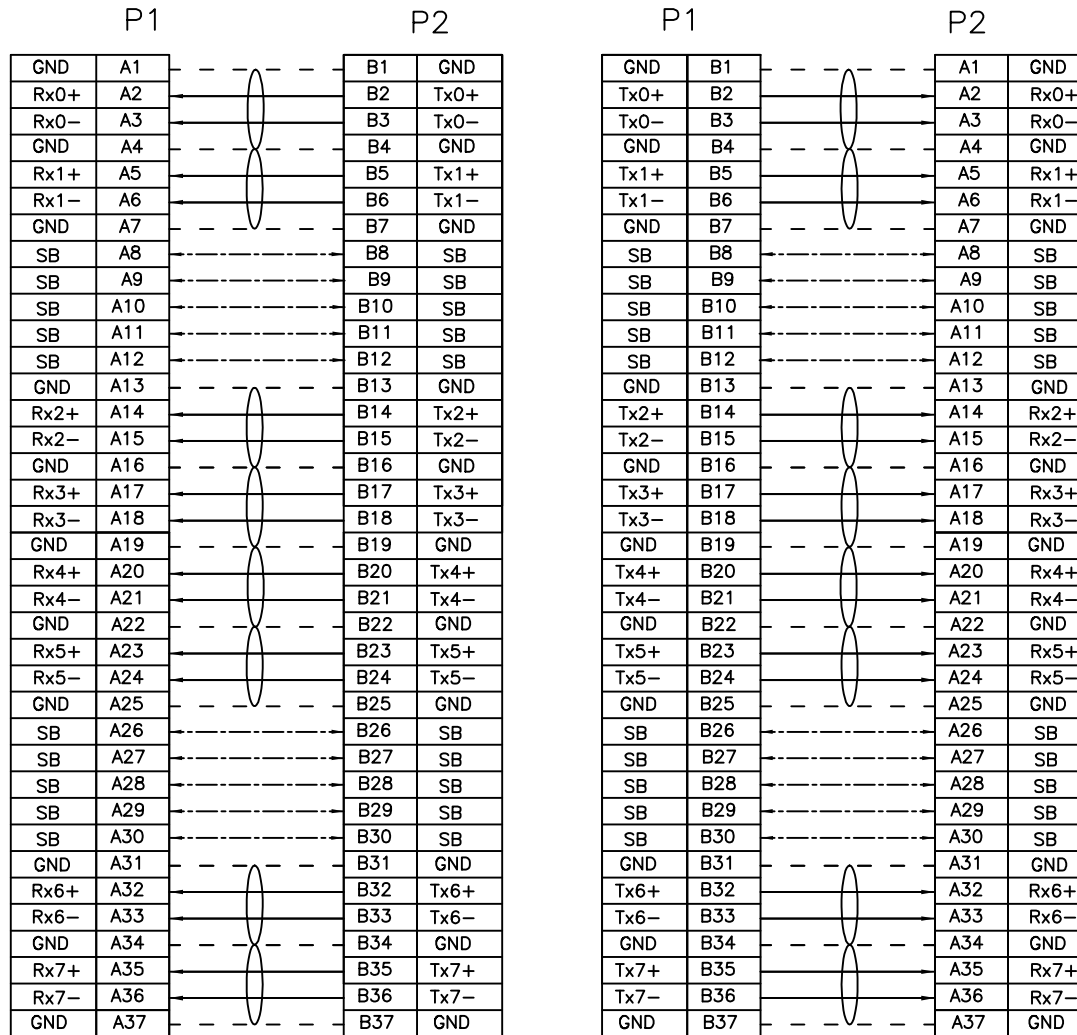

A1,A4,A7,A13,A16,A19,A22,A25,A31,A34,A37  
 B1,B4,B7,B13,B16,B19,B22,B25,B31,B34,B37 Grounded on PCB

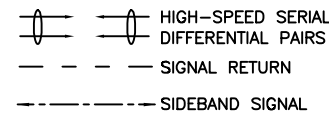

Tolerances	Dwg. No.	S0220220309-01	Part No.	<b>OUPIIN ENTERPRISE CO., LTD.</b>		
.x = ±0.50	Projection		SS8S+SS8SXLCMxxAxxGxx			
.xx = ±0.30	Unit <i>mm</i>	Scale	1:N			Title:
.xxx = ±0.15	Drawn By	Martin	03/09'22			Slim SAS 8i STR to SlimSAS 8i STR Cable ①517
SHEET		2/2	Ver.No.	X1		