

REV.	SPECIFICATION	ECN NO.	APPD.
R1			

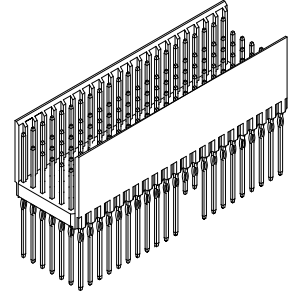
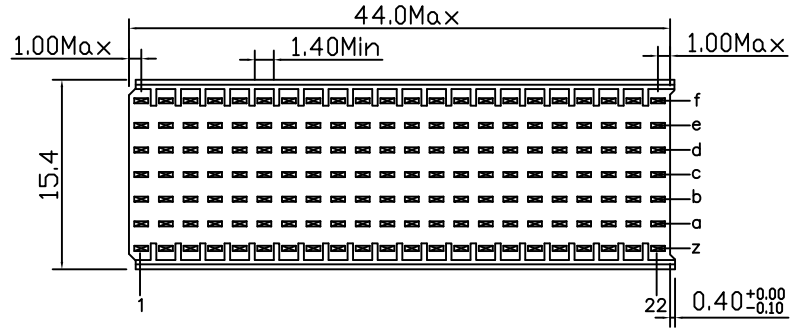

Material:

Housing: Thermoplastic Polyester Glass Filled UL94V-0
 Contacts: Copper Alloy.

Electrical Characteristics:

Current Rating: 1 AMP.
 Dielectric Withstanding Voltage: AC 750V For 1 minute.
 Insulator Resistance: 10000MΩ min.at DC 500V.
 Contact Resistance: 20mΩ max.at DC 100mA.
 Operating Temperature: -55°C ~ +125°C.

***RoHS Compliant**

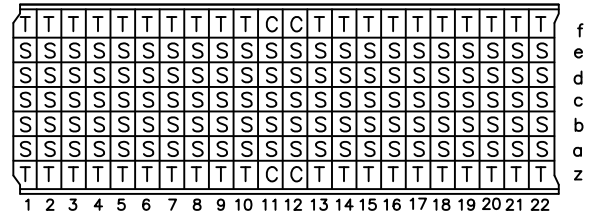
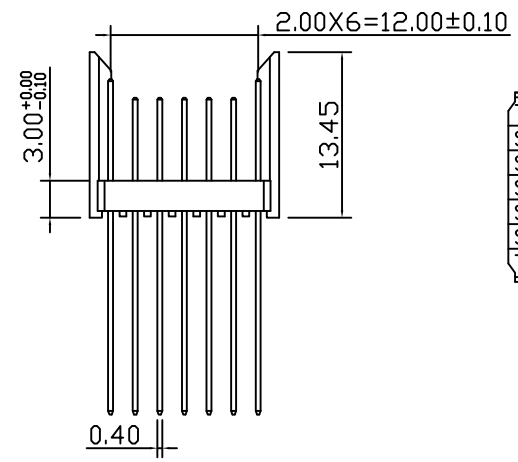
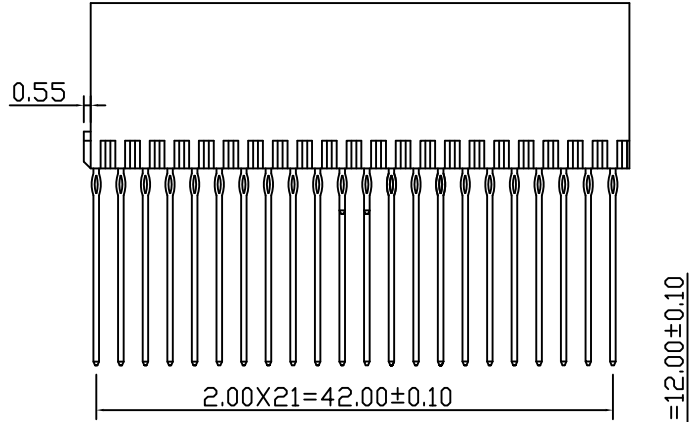

CONTACT LAYOUT

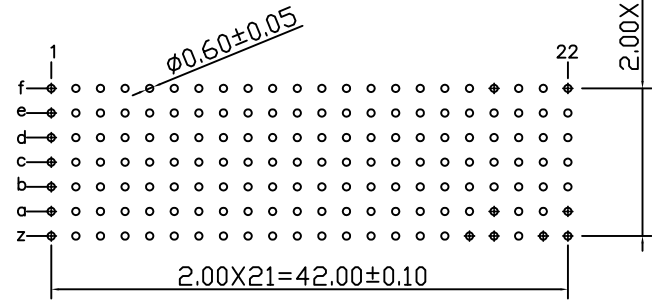

P.C. Board Layout
(Top View)

9111- 7 1 B 154 I C xx U
 Series 7Row 1: Male B: Type B Housing Type I: I Option U: Tube Package 10: 10 u" 30: 30 u" C: Dip Tin Contact Gold G: Gold

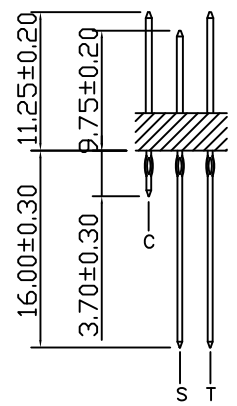

Tolerances	Dwg. No.	9111D71104	Title:	9111 Series 2.00 Hard Metric Connectors Male Type B-22	 OUPIN ELECTRONIC(KUNSHAN) CO., LTD. P/N: 9111-71B154ICxxU SHEET 1/1 Ver.No. R1
x = ±0.5	Projection				
.x = ±0.25	Unit	mm	Scale	1:1	
.xx = ±0.15	Drawn By	Zhu QL 08/15'12			