

REV.	SPECIFICATION	ECN NO.	APPD.

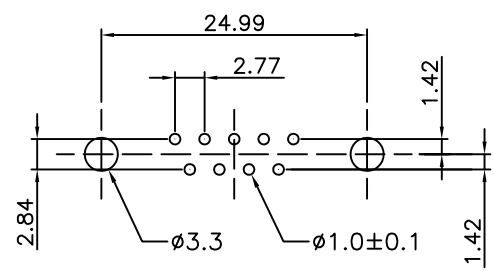
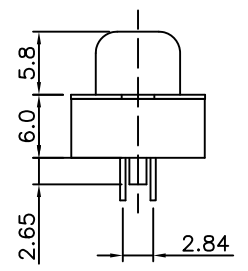
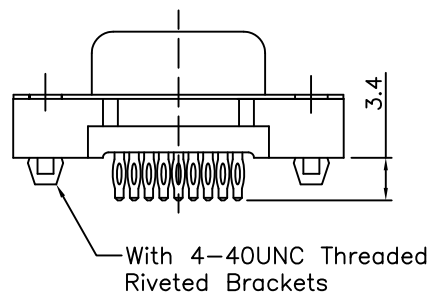
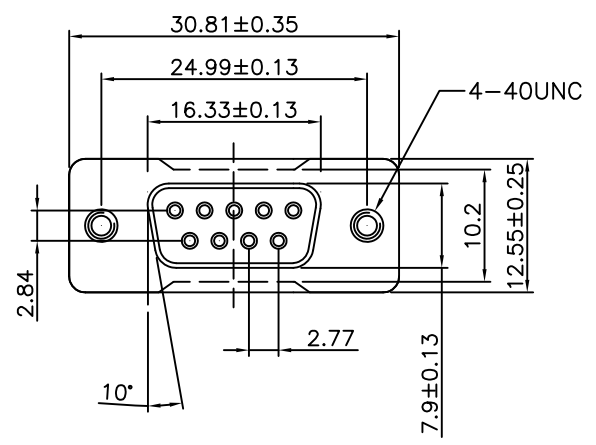

P.C.Board Layout

Material:

Housing: PBT, UL94V-0.
 Contacts: Brass, Gold Plated on Contact Area and 100u" Min Tin Plated on Solder Tail over Nickel 50 u" Min.
 Shell: Steel.

Electrical Characteristics:

Current Rating: 3 AMP.
 Dielectric Withstanding Voltage: AC 1000V For 1 minute..
 Insulation Resistance: 1000MΩ min. at DC 500V
 Contact Resistance: 20mΩ max. at DC 100mA.
 Operating Temperature: -55°C~+105°C.
***RoHS Compliant**

7905- 09 F T B P C 00 N3 A
 Series Position F: Female B: Black P: Press Fit Type C: Selective Gold Plated
 A: Tray Package
 N3: With 4-40UNC Threaded Riveted Brackets(Board Locks)
 00: G/F

Tolerances	Dwg. No.	7905D02018
x = ±0.5	Projection	
.x = ±0.25	Unit	mm
.xx = ±0.15	Scale	1:1
	Drawn By	jja-chi 01/03'18

Title:
 7905 Series
 D-SUB Straight
 Press fit type

OUPIIN ELECTRONIC(KUNSHAN) CO., LTD.			
P/N: 7905-09FTBPC00N3A			
SHEET	1/1	Ver.No.	A4