

歐品電子(昆山)有限公司
 OUPIIN ELECTRONIC(KUNSHAN) CO.,LTD.
 包裝作業規範
 PACKAGING SPECIFICATION

CONFIDENTIAL TOP SECRET

規格編號SPEC.NO.	Q9001SPP-219T1			PAGE	1/4	REV.	R
適用客戶 APPLICABLE CUSTOMER	ALL	適用產品 APPLICABLE PRODUCT	9001-16(30/20/10)1Cxx(L1)A		包裝方式 PACKAGING CATEGORY	TRAY PLATE PACKING	

修訂履歷 REVISION HISTORY

REV.	ECN NO	頁次 PAGE			
		1	2	3	4
R		Revise the quantity of the packing (修改包裝盤數量)		26盤/箱改为25盤/箱	

事業單位 DIVISION	產品開發部	核准 APPROVED	Peter Zhu	審核 CHECKED	Nita Lu	制表 PREPARED	Martin 04/26'23
------------------	-------	----------------	-----------	---------------	---------	----------------	-----------------

歐品電子(昆山)有限公司
 OUPIIN ELECTRONIC(KUNSHAN) CO.,LTD.
 包裝作業規範
 PACKAGING SPECIFICATION

<input checked="" type="checkbox"/>	CONFIDENTIAL	<input type="checkbox"/>	TOP SECRET
PAGE	2/4	REV.	R

規範編號SPEC.NO. Q9001SPP-219T1

包裝作業圖示及說明 PACKING OPERATION DIAGRAM & INSTRUCTION	備注 REMARK
--	--------------

Laying Product Diagram:
 (產品擺放圖示)



- 一.PVC Plate Packing Mode:
(PVC盤包裝方式)
- (1).CT-1.6 Box: PVC-10 XX PCS.
(CT-1.6 規格的紙箱放PVC-10盤 XX PCS)
 - (2).Put product in each trough fully as shown in diagram.
(產品在盤子中擺放方式如圖所示)
 - (3).After each dish is filled with products,it is folded up and the product is empty on the top of the mouth
(每盤放滿產品後疊起,最上面一層放空底盤)
 - (4).Stack the XX PVC plates filled with product, put them in the paper box in which has been put waterproof bag.
(將放滿產品的XX個PVC盤疊起,裝入防水袋放入紙箱內)

歐品電子(昆山)有限公司

OUPIIN ELECTRONIC(KUNSHAN) CO.,LTD.

包裝作業規範

PACKAGING SPECIFICATION

CONFIDENTIAL TOP SECRET

規範編號SPEC.NO. Q9001SPP-219T1

PAGE 3/4 REV. R

包裝作業圖示及說明

PACKING OPERATION DIAGRAM & INSTRUCTION

備注

REMARK

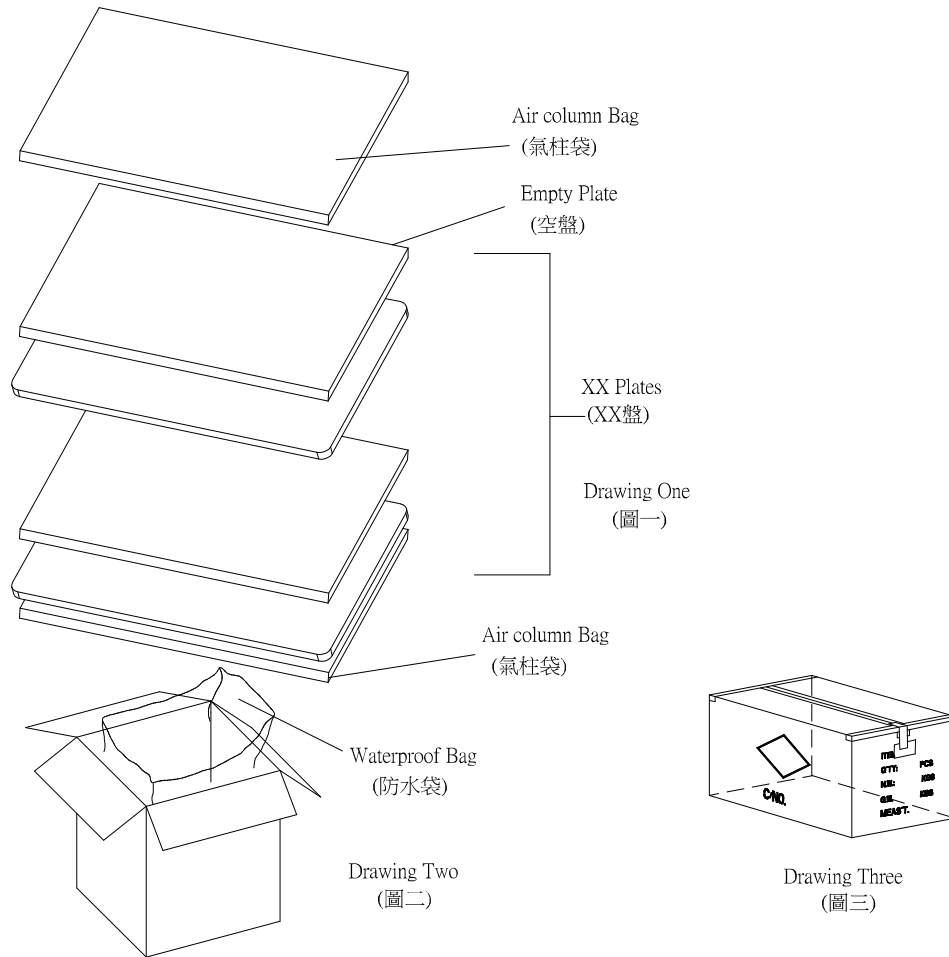

一. Outer Box Packing Mode:

(外箱包裝方式)

- (1). Paper box 1.6 standard 1 PCS, as shown in drawing Two.
(紙箱1.6規格 1 PCS. 如(圖二)所示)
- (2). Put one Air column bag in the upper and lower of the paper box,, 2PCS in all., as shown in drawing One.
(每箱上下各放一塊氣柱袋, 共2PCS, 如(圖一)所示)
- (3). Put 1 PCS waterproof in the paper box, as shown in drawing Two.
(紙箱內側放入防水袋 1 PCS. 如(圖二)所示)
- (4). Piled the XX packing plates packed up in the waterproof.
(將放滿產品的XX個PVC盤疊起, 裝入防水袋內)
- (5). Seal the waterproof bag, then put the Air column bag 1PCS on the bag.
(Put 1 PCS Air column bag at the right and left side in the paper box if it is necessary.)
(封上防水袋, 然後放上第二塊氣柱袋)
(必要時, 在紙箱的左右兩側各放一塊氣柱袋)
- (6). Seal the surface of the outer box, as shown in drawing Three.
(將外箱上層封口. 如(圖三)所示)

The form on the right and flank side of the box must be filled correctly and clearly, take actual testing weight as the standard of each box gross weight.

外箱之正麥和側麥所要填寫之項目要填寫正確, 清晰, 每箱之毛重應以實測重量為準.

歐品電子(昆山)有限公司

OUPIIN ELECTRONIC(KUNSHAN) CO.,LTD.

PACKAGING SPECIFICATION (包裝作業規範)

CONFIDENTIAL TOP SECRET

SPEC.NO.(規範編號)	Q9001SPP-219T1								PAGE:	4/4	REV.	R
----------------	----------------	--	--	--	--	--	--	--	-------	-----	------	---

PACKING MATERIAL (包裝材料)			PRODUCT P/N	CT NO.	PACKING N.W.	PACKING QUANTITY (包裝數量)			WEIGHT (重量) kg		
MATERIAL NAME (材料名稱)	PART NO. (料號)	Q'TY	(產品料號)	(紙箱規格)	(包材重量)	PCS/TRAY	TRAY/BOX	PCS/BOX	N.W./PCS	N.W./BOX	G.W./BOX
PAPER BOXES (紙箱)	CT-1.6	1	9001-16301CxxA	CT-1.6	3.47	100	25	2500	0.00601	15.03	18.50
Packing Box (包裝盒)	PVC-10	----									
WATERPROOF BAG (防水袋)	PE-100*90	1									
Air column BAG (氣柱袋)	-----	2									
DRYING AGENT (干燥劑)	-----	3									

1.NOTE: (注意):It is folded up and the product is empty on the top of the mouth (最上一層另外放一個空盤)

When the finished products have been made,take the actual weight as the standard of gross weight in each box.

(成品出貨時,每箱之毛重應以實測重量為準)

When the finished products have been made,stick the proper designation list on the box according to product demand.

(成品出貨時,依據出貨要求貼上相對應的標籤單)

It doesn't influence the manner of packing with the gold-plated way to print word way,Can amalgamate.

(印字方式跟鍍金方式不影響包裝方式,可以共用)