

# 歐品電子(昆山)有限公司

OUPIIN ELECTRONIC(KUNSHAN) CO.,LTD.

## PACKAGING SPECIFICATION (包裝作業規範)

CONFIDENTIAL  TOP SECRET

SPEC.NO.(規範編號) Q9392SPP-1311		APPLICABLE CUSTOMER (適用客戶) ALL		APPLICABLE PRODUCT (適用產品) 9392- 4S28P3xCB30DA		PAGE 1/4	REV. A
						PACKAGING CATEGORY (包裝方式)	TRAY PLATE PACKING

### REVISION HISTORY (修訂履歷)

ECN REV. NO	PAGE (頁次)								
	1	2	3	4					
A	NEW 新品发行								

DIVISION (事業單位)	Product Development (產品開發課)	APPROVED (核准)	CHECKED (審核)	DE: PE:	PREPARED (制表)	GYJ 05/30'23
-----------------	-----------------------------	---------------	--------------	---------	---------------	--------------

# 歐品電子(昆山)有限公司

OUPIIN ELECTRONIC(KUNSHAN) CO.,LTD.

## PACKAGING SPECIFICATION (包裝作業規範)

SPEC.NO.(規範編號) Q9392SPP-1052

CONFIDENTIAL TOP SECRET

PAGE 2/4 REV. A

### PACKING OPERATION DIAGRAM & INSTRUCTION (包裝作業圖示及說明)

### REMARK (備注)

#### Laying Product Diagram:

(產品擺放圖示)

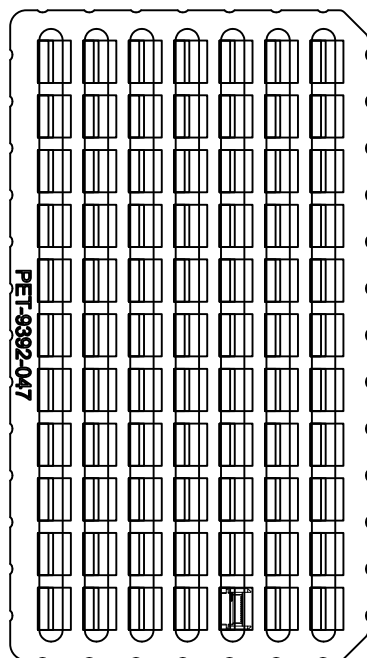

(Drawing 1-1)  
(圖1-1)

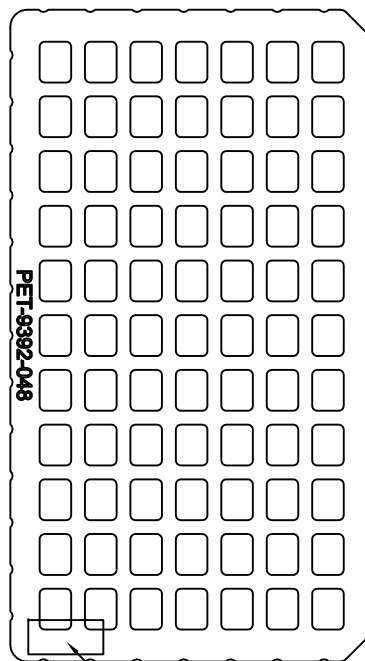

Batch label  
批次標籤

(Drawing 2)  
(圖2)

#### 一.PET Plate Packing Mode:

(PET盤包裝方式)

(1).CT-0.9 Box: PET-9392-047 xx PCS.

(CT-0.9規格的紙箱放PET-9392-047 盤 xx PCS)

(2).Put product in each trough fully as shown in diagram.  
(產品在盤子中擺放方式如圖所示)

(3).After filling each trough with product fully,cover it with transparent upper cover PET-9392-048 1PCS.  
The cover should be booked with the chassis together with the sticky tape, so as not to cause the products to fall scattered.  
(每盤放滿產品後,加蓋透明上蓋 PET-9392-048 1PCS)  
蓋子要與底盤用膠帶粘在一起, 以免造成產品散落。)

(4).The Batch label is stuck on each cover( such as Fig. 2).  
(在每個蓋子的上面貼批次標籤(樣式如圖2))

(5).Stack the xx PET plates filled with product, put them in the paper box in which has been put waterproof bag.  
(將放滿產品的 xx 個PET盤疊起,裝入防水袋放入紙箱內)

# 歐品電子(昆山)有限公司

OUPIIN ELECTRONIC(KUNSHAN) CO.,LTD.

PACKAGING SPECIFICATION (包裝作業規範)

<input checked="" type="checkbox"/> CONFIDENTIAL		<input type="checkbox"/> TOP SECRET	
PAGE	3/4	REV.	A

SPEC.NO.(規範編號) Q9392SPP-1311

## PACKING OPERATION DIAGRAM & INSTRUCTION (包裝作業圖示及說明)

## REMARK (備注)

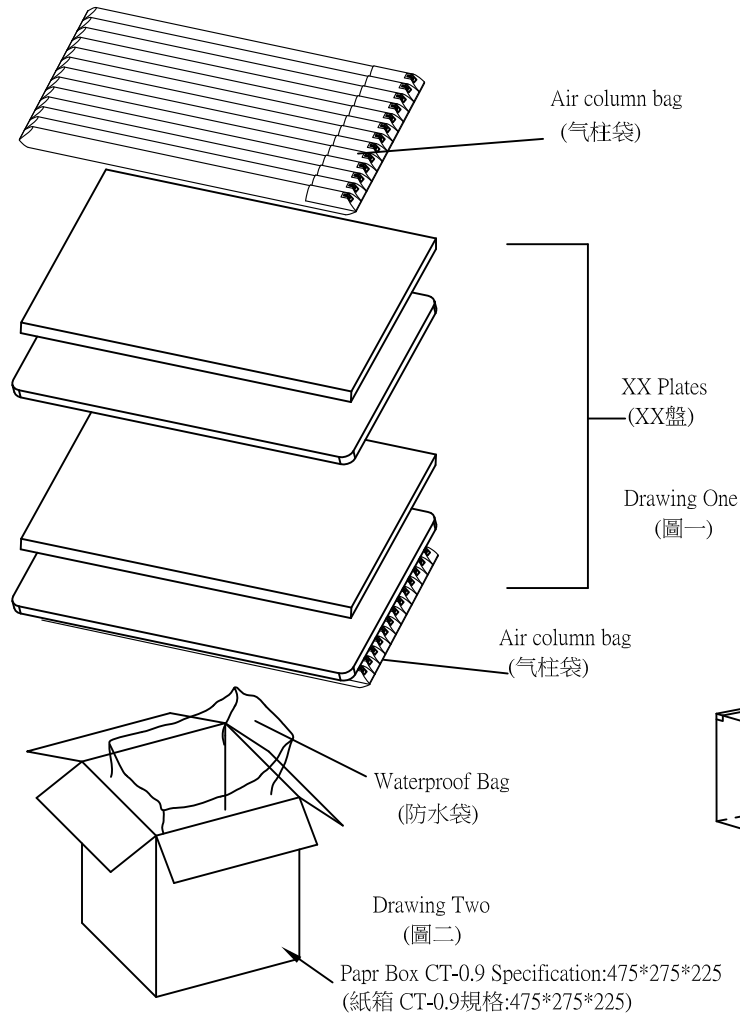

### 一. Outer Box Packing Mode:

(外箱包裝方式)

- (1). Paper box 0.9 standard 1 PCS, as shown in drawing Two.  
(紙箱 0.9 規格 1 PCS. 如(圖二)所示)
- (2). Put one Air column bag in the upper and lower of the paper box, 2PCS in all, as shown in drawing One.  
(每箱上下各放一塊气柱袋共2PCS, 如(圖一)所示)
- (3). Put 1 PCS waterproof in the paper box, as shown in drawing Two.  
(紙箱內側放入防水袋 1 PCS. 如(圖二)所示)
- (4). Piled the XX packing plates packed up in the waterproof.  
(將放滿產品的XX個PET盤疊起, 裝入防水袋內)
- (5). Seal the waterproof bag, then put the Air column bag 1PCS on the bag, if box can not be filled, filled with ploy.  
(Put 1 PCS Air column bag at the right and left side in the paper box if it is necessary.)

封上防水袋後, 放上第二塊气柱袋, 未填滿處用气柱袋填滿。  
(必要時, 在紙箱的左右兩側各放一塊气柱袋)

- (6). Seal the surface of the outer box, as shown in drawing Three.  
(將外箱上層封口. 如(圖三)所示)

- (7). The form on the right and flank side of the box must be filled correctly and clearly, take actual testing weight as the standard of each box gross weight.

外箱之正麥和側麥所要填寫之項目要填寫正確, 清晰, 每箱之毛重應以實測重量為準。

# 歐品電子(昆山)有限公司

OUPIIN ELECTRONIC(KUNSHAN) CO.,LTD.

## PACKAGING SPECIFICATION (包裝作業規範)

CONFIDENTIAL     TOP SECRET

PAGE: 4/4    REV. A

SPEC.NO.(規範編號) Q9392SPP-1311

PACKING MATERIAL (包裝材料)			PRODUCT P/N	CT NO.	PACKING N.W.	PACKING QUANTITY (包裝數量)			WEIGHT (重量) kg		
MATERIAL NAME (材料名稱)	PART NO. (料號)	Q'TY	(產品料號)	(紙箱規格)	(包材重量)	PCS/TRAY	TRAY/BOX	PCS/BOX	N.W./PCS	N.W./BOX	G.W./BOX
PAPER BOXES (紙箱)	CT-0.9	1	9392-4S28P32CB30DA	CT-0.9	4.49	77	13	1001	0.0033	3.30	7.79
Packing Box (包裝盒)	PET-9392-047	----									
Packing Box Cover (包裝盒蓋子)	PET-9392-048	----									
WATERPROOF BAG (防水袋)	PE 100*70	1									
Air column bag (氣柱袋)	-----	2									
DRYING AGENT (干燥劑)	-----	3									

1.NOTE:

(注意)

When the finished products have been made,take the actual weight as the standard of gross weight in each box.(成品出貨時,每箱之毛重應以實測重量為準)

When the finished products have been made,stick the proper designation list on the box according to product demand.(成品出貨時,依據出貨要求貼上相對應的標籤單)

It doesn't influence the manner of packing with the gold-plated way to print word way,Can amalgamate.(印字方式跟鍍金方式不影響包裝方式,可以共用)