

歐品電子(昆山)有限公司

OUPIIN ELECTRONIC(KUNSHAN) CO.,LTD.

PACKAGING SPECIFICATION (包裝作業規範)

CONFIDENTIAL TOP SECRET

SPEC.NO.(規範編號) Q9393SPP-1332		APPLICABLE CUSTOMER (適用客戶) ALL		APPLICABLE PRODUCT (適用產品) 9393-K2A2P11ACxxDA		PAGE 1/4	REV. A
						PACKAGING CATEGORY (包裝方式)	TRAY PLATE PACKING

REVISION HISTORY (修訂履歷)

ECN REV. NO	PAGE (頁次)								
	1	2	3	4					
A	NEW (新版)								

DIVISION (事業單位)	Product Development (產品開發課)	APPROVED (核准)	CHECKED (審核)	PE:	PREPARED (制表)	GYJ 06/06'23
				DE:		

歐品電子(昆山)有限公司

OUPIIN ELECTRONIC(KUNSHAN) CO.,LTD.

PACKAGING SPECIFICATION (包裝作業規範)

■ CONFIDENTIAL □ TOP SECRET

SPEC.NO.(規範編號) Q9393SPP-1332

PAGE

2/4

REV.

A

PACKING OPERATION DIAGRAM & INSTRUCTION (包裝作業圖示及說明)

REMARK (備注)

Laying Product Diagram: (產品擺放圖示)

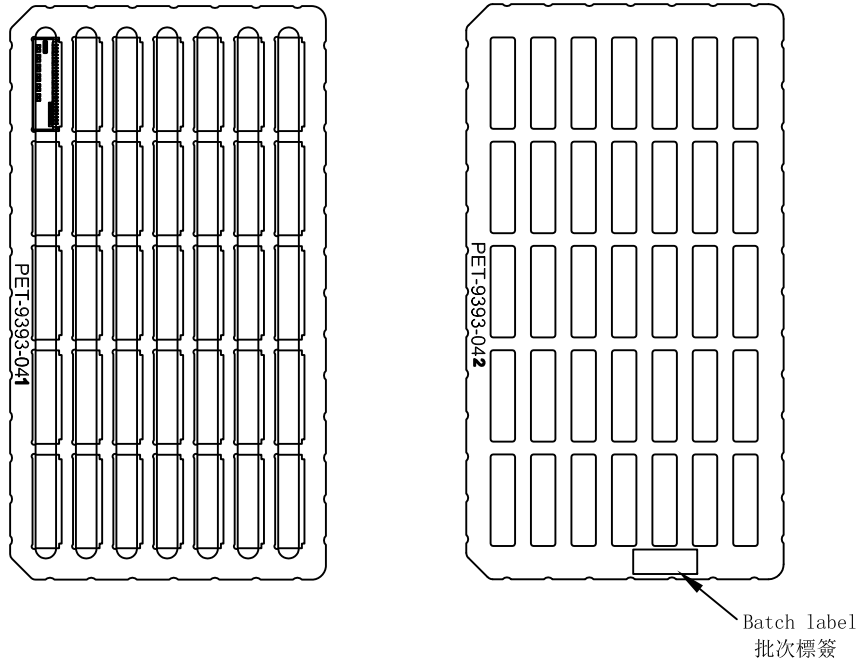

(Drawing 1)
(圖1)

一.PET Plate Packing Mode: (PET盤包裝方式)

(1).CT-0.9 Box: PET-9393-041 xx PCS.

(CT-0.9規格的紙箱放PET-9393-041盤 xx PCS)

(2).Put product in each trough fully as shown in diagram.
(產品在盤子中擺放方式如圖所示)

(3).After filling each trough with product fully,cover it
with transparent upper cover PET-9393-042 1PCS。
(每盤放滿產品後,加蓋透明上蓋 PET-9393-042 1PCS)

(4)The Batch label is stuck on each cover(such as Fig. 1).
在每個蓋子的上面貼批次標籤(如圖1)

(5).Stack the XX PET plates filled with product, put them in
the paper box in which has been put waterproof bag.
(將放滿產品的XX個PET盤疊起,裝入防水袋放入紙箱內)

歐品電子(昆山)有限公司

OUPIIN ELECTRONIC(KUNSHAN) CO.,LTD.

PACKAGING SPECIFICATION (包裝作業規範)

<input checked="" type="checkbox"/> CONFIDENTIAL		<input type="checkbox"/> TOP SECRET	
PAGE	3/4	REV.	A

SPEC.NO.(規範編號) Q9393SPP-1332

PACKING OPERATION DIAGRAM & INSTRUCTION (包裝作業圖示及說明)

REMARK (備注)

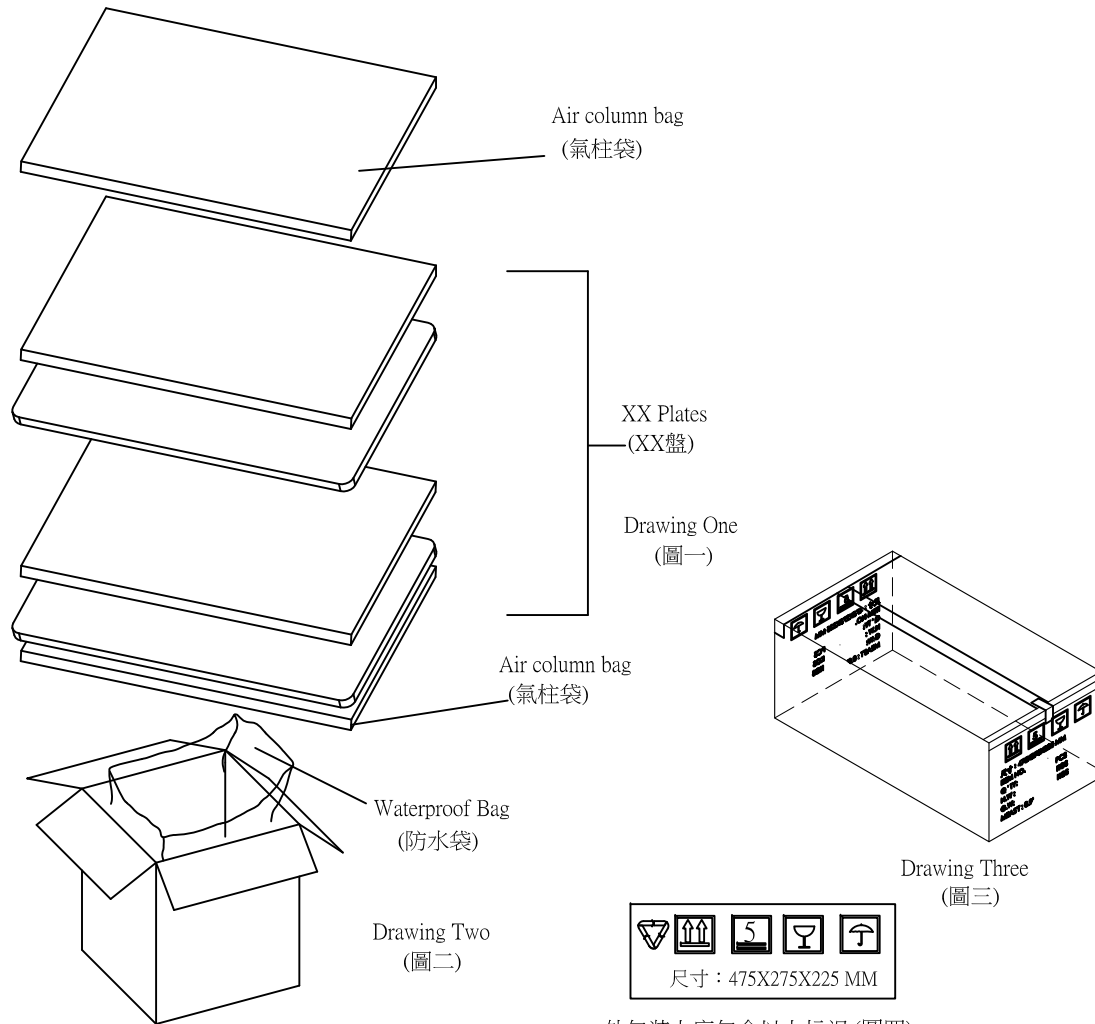

外包裝上應包含以上标识 (圖四)

一. Outer Box Packing Mode:

(外箱包裝方式)

- (1). Paper box 0.9 standard 1 PCS, as shown in drawing Two.
(紙箱 0.9 規格 1 PCS, 如(圖二)所示)
- (2). Put one Air column bag in the upper and lower of the paper box, 2PCS in all, as shown in drawing One.
(每箱上下各放一塊氣柱袋, 共2PCS, 如(圖一)所示)
- (3). Put 1 PCS waterproof in the paper box, as shown in drawing Two.
(紙箱內側放入防水袋 1 PCS, 如(圖二)所示)
- (4). Stack the XX PET plates filled with product, put them in the waterproof.
(將放滿產品的XX個PET盤疊起, 裝入防水袋內)
- (5). Seal the waterproof bag, then put the Air column bag 1PCS on the bag. if box can not be filled, filled with ploy.
(Put 1 PCS Air column bag at the right and left side in the paper box if it is necessary.)
封上防水袋後, 放上第二塊氣柱袋, 未填滿處用保麗龍填滿。
(必要時, 在紙箱的左右兩側各放一塊氣柱袋)
- (6). Seal the surface of the outer box, as shown in drawing Three.
(將外箱上層封口, 如(圖三)所示)
- (7). Outer packing should include mark as shown in drawing four
(外包裝上應包含圖四所示标识內容)

The form on the right and flank side of the box must be filled correctly and clearly, take actual testing weight as the standard of each box gross weight.

外箱之正麥和側麥所要填寫之項目要填寫正確, 清晰, 每箱之毛重應以實測重量為準。

歐品電子(昆山)有限公司

OUPIN ELECTRONIC(KUNSHAN) CO.,LTD.

PACKAGING SPECIFICATION (包裝作業規範)

CONFIDENTIAL TOP SECRET

SPEC.NO.(規範編號)		Q9393SPP-1332						PAGE:	4/4	REV.	A
PACKING MATERIAL (包裝材料)			PRODUCT P/N	CT NO.	PACKING N.W.	PACKING QUANTITY (包裝數量)			WEIGHT (重量) kg		
MATERIAL NAME (材料名稱)	PART NO. (料號)	Q'TY	(產品料號)	(紙箱規格)	(包材重量)	PCS/TRAY	TRAY/BOX	PCS/BOX	N.W./PCS	N.W./BOX	G.W./BOX
PAPER BOXES (紙箱)	CT-0.9	1	9393-K2A2P11ACxxDA	CT-0.9	2.13	35	18	630	0.0136	8.57	10.70
Packing Box (包裝盒)	PET-9393-041	----									
Packing Box Cover (包裝盒蓋子)	PET-9393-042	----									
WATERPROOF BAG (防水袋)	PE 100*70	1									
Air column bag (氣柱袋)	-----	2									
DRYING AGENT (干燥劑)	-----	3									

1.NOTE:
 (注意)
 When the finished products have been made,take the actual weight as the standard of gross weight in each box.
 (成品出貨時,每箱之毛重應以實測重量為準)
 When the finished products have been made,stick the proper designation list on the box according to product demand.
 (成品出貨時,依據出貨要求貼上相對應的標籤單)