

# 歐品電子(昆山)有限公司

OUPIIN ELECTRONIC(KUNSHAN) CO.,LTD.

PACKAGING SPECIFICATION (包裝作業規範)

CONFIDENTIAL  TOP SECRET

SPEC.NO.(規範編號) Q8206SPP-902

PAGE 1/4 REV. A

APPLICABLE CUSTOMER (適用客戶) ALL

APPLICABLE PRODUCT (適用產品) 8206-2X50CxxRPT 8206-2X50CxxRP1T

PACKAGING CATEGORY (包裝方式)

TAPE REEL

## REVISE HISTORY (修訂履歷)

REV. / ECN NO.	頁次 PAGE								
	1	2	3	4					
A	New (新版發行)								

DIVISION (事業單位) Product Develop (產發部產品開發課)

APPROVED (核准)

CHECKED (審核)

PREPARED (制表) LQ 09/16'17

# 歐品電子(昆山)有限公司

OUPIIN ELECTRONIC(KUNSHAN) CO.,LTD.

PACKAGING SPECIFICATION (包裝作業規範)

<input checked="" type="checkbox"/> CONFIDENTIAL <input type="checkbox"/> TOP SECRET	
PAGE	2/4
REV.	A

SPEC.NO.(規範編號) Q8206SPP-902

## PACKING OPERATION DIAGRAM & INSTRUCTION (包裝作業圖示及說明)

## REMARK (備注)

### Heat plastic-band packing manner 封帶包裝方式

The road hole must be laid at the right of the drawing direction.  
(導向圓孔必須設在拉延方向的右側)

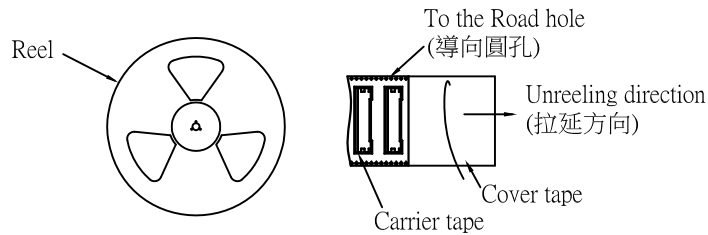

The begining of the band , the detailed chart of the end.  
(封帶開始部分，結束部分的詳細圖)

Lead Section (開始部分)	Drawing Section (拉延部分)	End Section (結束部分)
Blank Section (未封裝部分) (160mm)	Packing Section (封裝部分) (350 Pcs)	Blank Section (未封裝部分) (100mm)

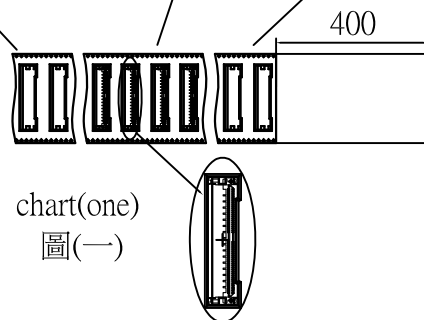

chart(one)  
圖(一)

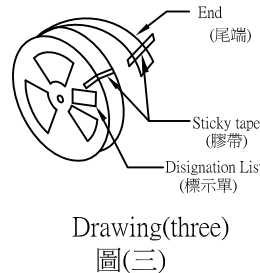
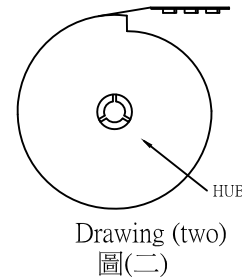

### 一.Packing of interior box: (內盒包裝方式)

(1)Packaging way of each reel is shown in drawingone.  
(每個REEL包裝方式,如圖(一)所示)

(2) At the beginning of winding belt,take one part of sticky belt with 60 mm length,15mm width. stick 20 mm on the material belt,stick 40 mm on the gap of the REEL mandrel , as shown in drawing two.  
(在開始纏繞料帶時,取長60mm寬15mm之膠帶一段,20mm 黏于料帶上,40mm 黏于REEL心軸之缺口上,如圖(二)所示)

(3) Use one REEL can package 350 PCS products .  
(每卷REEL可包裝350PCS產品)

(4)After winding the material belt, stick the COVER TAPE with 60 mmlength, 15 mm width stick belt, and fix it on the circumference of the REEL,as shown in drawing three.  
(料帶卷繞完成時取長60mm寬15mm之3M膠帶黏住COVER TAPE并將其固定在REEL之圓周上,如圖(三)所示)

\*. Stick sticky belt(18mm width,40 length) on the two sides when COVER TAPE is interrupted, stick each end with20 mm belt to get them together.and the two COVER TAPE connected must be at the same line.  
(COVER TAPE 有中斷時可用寬18mm,長40mm之膠帶將中斷之兩端各貼20mm,使其連接為一體.但連接后的兩段COVER TAPE應在同一直線上.)

# 歐品電子(昆山)有限公司

OUPIIN ELECTRONIC(KUNSHAN) CO.,LTD.

PACKAGING SPECIFICATION (包裝作業規範)

<input checked="" type="checkbox"/> CONFIDENTIAL		<input type="checkbox"/> TOP SECRET	
PAGE	3/4	REV.	A

SPEC.NO.(規範編號) Q8206SPP-902

PACKING OPERATION DIAGRAM & INSTRUCTION (包裝作業圖示及說明)	REMARK (備注)
---	-------------

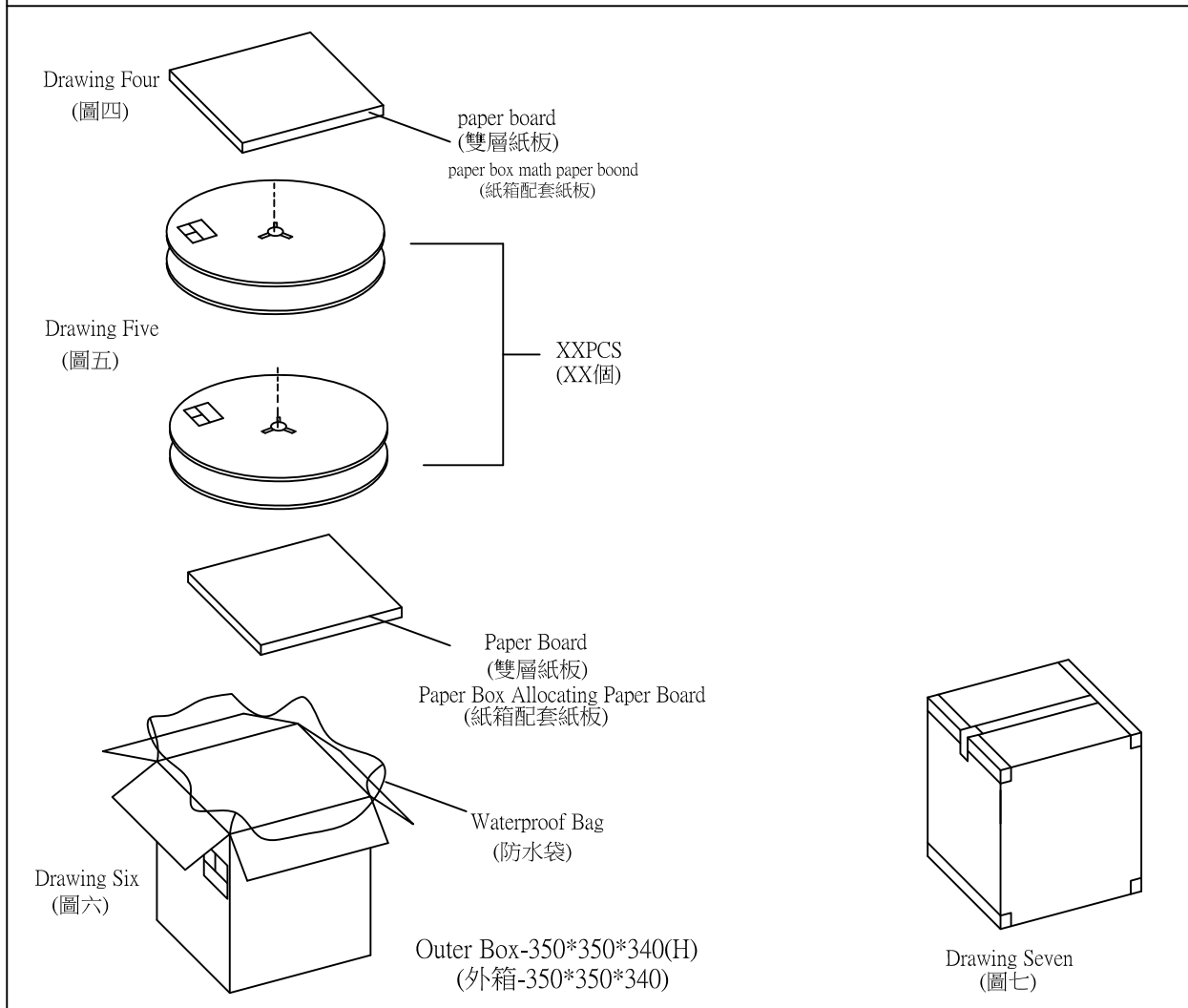

2.Outer box packing mode:  
(二.外箱包裝方式)

- (1)Paper box(CT-1.5)1PCS( Drawing Six).  
(紙箱CT-1.51PCS圖六).
- (2).Put 1pcs allocating paper borad at the bottom of the box , then put 1 PCS waterproof bag on the board( Drawing Six).  
(底層放入紙箱配套紙板1PCS.上面放入防水袋1PCS(圖六).
- (3).After folding 4pieces of reel disk, seal the waterproof bag(Drawing Five).  
(疊好4個Reel盤後封上防水袋圖五).
- (4).Put 1PCS double decked paper board on the top of box(Drawing Four).  
(最上層放入雙層紙板1PCS圖四).
- (5)Seal the surface of the outer box (Drawing Seven).  
(將外箱上層封口圖七).

\*The form on the right and flank side of the box must be filled correctly and clearly,take actual testing weight as the standard of every box gross weight.  
(\*外箱之正面和側面所要填寫之項目要填寫正確,清晰,每箱之毛重應以實測重量為準.)

# 歐品電子(昆山)有限公司

## OUPIIN ELECTRONIC(KUNSHAN) CO.,LTD.

### PACKAGING SPECIFICATION (包裝作業規範)

CONFIDENTIAL     TOP SECRET

SPEC.NO.(規範編號)		Q8206SPP-902										PAGE: 4/4		REV. A	
PACKING MATERIAL (包裝材料)			PRODUCT P/N	TAPE REEL STANDARD	PACKING P/N	PACKING N.W.	PACKING QUANTITY (包裝數量)			WEIGHT (重量) kg					
MATERIAL NAME (材料名稱)	PART NO. (料號)	Q'TY	(產品料號)	(包材規格mm)	(包材料號)	(包材重量)	PCS/REEL	REEL/BOX	PCS/BOX	N.W./PCS	N.W./BOX	G.W./BOX			
PAPER BOXES (紙箱)	CT-1.5	1	8206-2X50CxxRPT	72	8206-K10072-001	3.46	350	4	1400	0.0026418	3.69852	7.16			
WATERPROOF BAG (防水袋)	100*70	1			COVER-K0072-001										
DOUBLE DECKED PAPER BOARD (雙層紙板)	340*340*5	2	8206-2X50CxxRP1T	72	8206-K10072-001	3.46	350	4	1400	0.0026418	3.69852	7.16			
					COVER-K0072-001										
3M FIBER BELT (3M纖維膠帶)	-----	-----													
DRYING AGENT (干燥劑)	-----	3													

1.NOTE:  
(注意)

When the finished products have been made,take the actual weight as the standard of gross weight in each box.

(成品出貨時,每箱之毛重應以實測重量為準)

When the finished products have been made,stick the proper designation list on the box according to product demand.

(成品出貨時,依據出貨要求貼上相對應的標籤單)

It doesn't influence the manner of packing with the gold-plated way to print word way.Can amalgamate.

(印字方式跟鍍金方式不影響包裝方式,可以共用)

2.NOTE:

(注意)

\*Pay attention to each big reel of material ,can be divided into 3 small reels,consumption of each big reel can't exceed 1meter, or the third reel can't be packed

(來料每大卷reel (carrier tape) 平均可分3小卷reel ,每大卷reel 消耗量不可超過1米,否則第三小卷不可包裝.)