

歐品電子(昆山)有限公司

OUPIIN ELECTRONIC(KUNSHAN) CO.,LTD.

PACKAGING SPECIFICATION (包裝作業規範)

SPEC.NO.(規範編號)	8932SPP	適用產品: 8932-J125215GAAxxSB	PAGE	1/1	REV.	I780-A1
----------------	---------	---------------------------	------	-----	------	---------

PACKING OPERATION DIAGRAM & INSTRUCTION (包裝作業圖示及說明)

REMARK (備註)

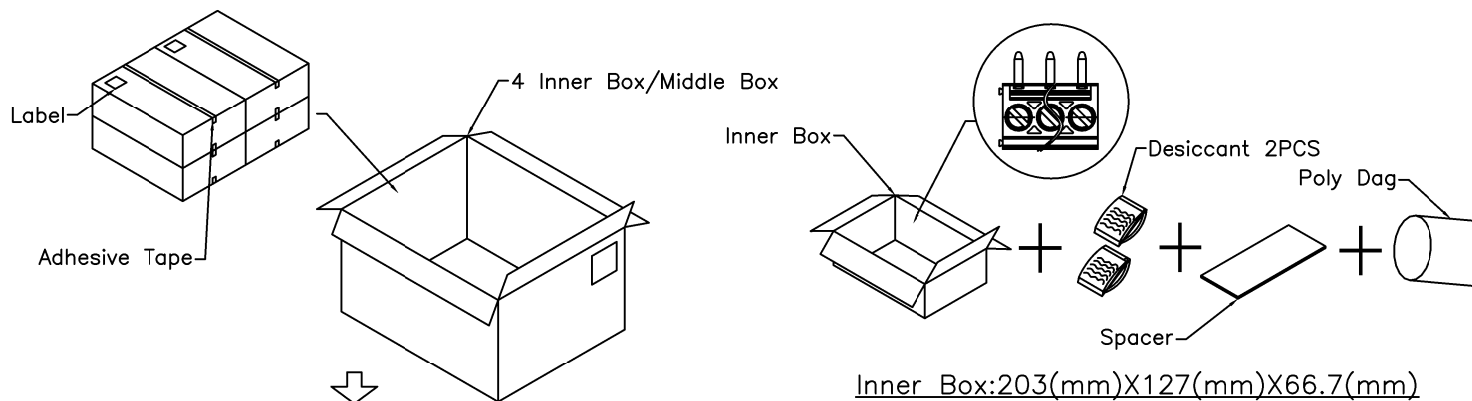

Packing:

Positions	Pcs/ Inner Box	Pcs/ Middel Box	Pcs/ Carton	Carton: N.W: kg	Carton: G.W: kg
02P	170	680	2040	10.77	12.77
03P	100	400	1200	9.50	11.50
04P	80	320	960	10.14	12.14
05P	75	300	900	11.88	13.88
06P	60	240	720	11.40	13.40
07P	45	180	540	9.98	11.98
08P	45	180	540	11.40	13.40
09P	35	140	420	9.98	11.98
10P	30	120	360	9.52	11.52
11P	30	120	360	10.45	12.45
12P	30	120	360	11.40	13.40
13P	20	80	240	8.24	10.24
14P	20	80	240	8.87	10.87
15P	20	80	240	9.50	11.50
16P	20	80	240	10.14	12.14
20P	20	80	240		
21P	20	80	240	13.91	15.91
24P	20	80	240	15.87	17.87

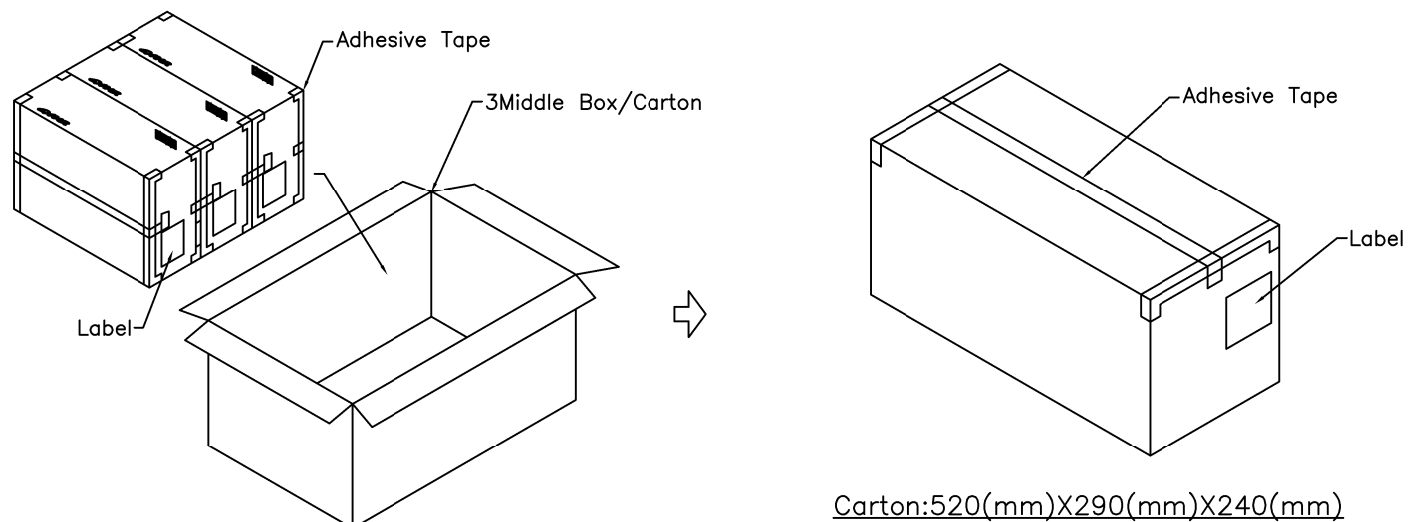

Middle Box:270(mm)X230(mm)X160(mm)

Drawn By: Emma 08/26'20