

# 歐品電子(昆山)有限公司

OUPIIN ELECTRONIC(KUNSHAN) CO.,LTD.

PACKAGING SPECIFICATION (包裝作業規範)

SPEC.NO.(規範編號)	8949SPP-F11010	適用產品: 8949-F11010-06SBNA-HT	PAGE	1/1	REV.	I563
----------------	----------------	-----------------------------	------	-----	------	------

PACKING OPERATION DIAGRAM & INSTRUCTION (包裝作業圖示及說明)	REMARK (備註)
---	-------------

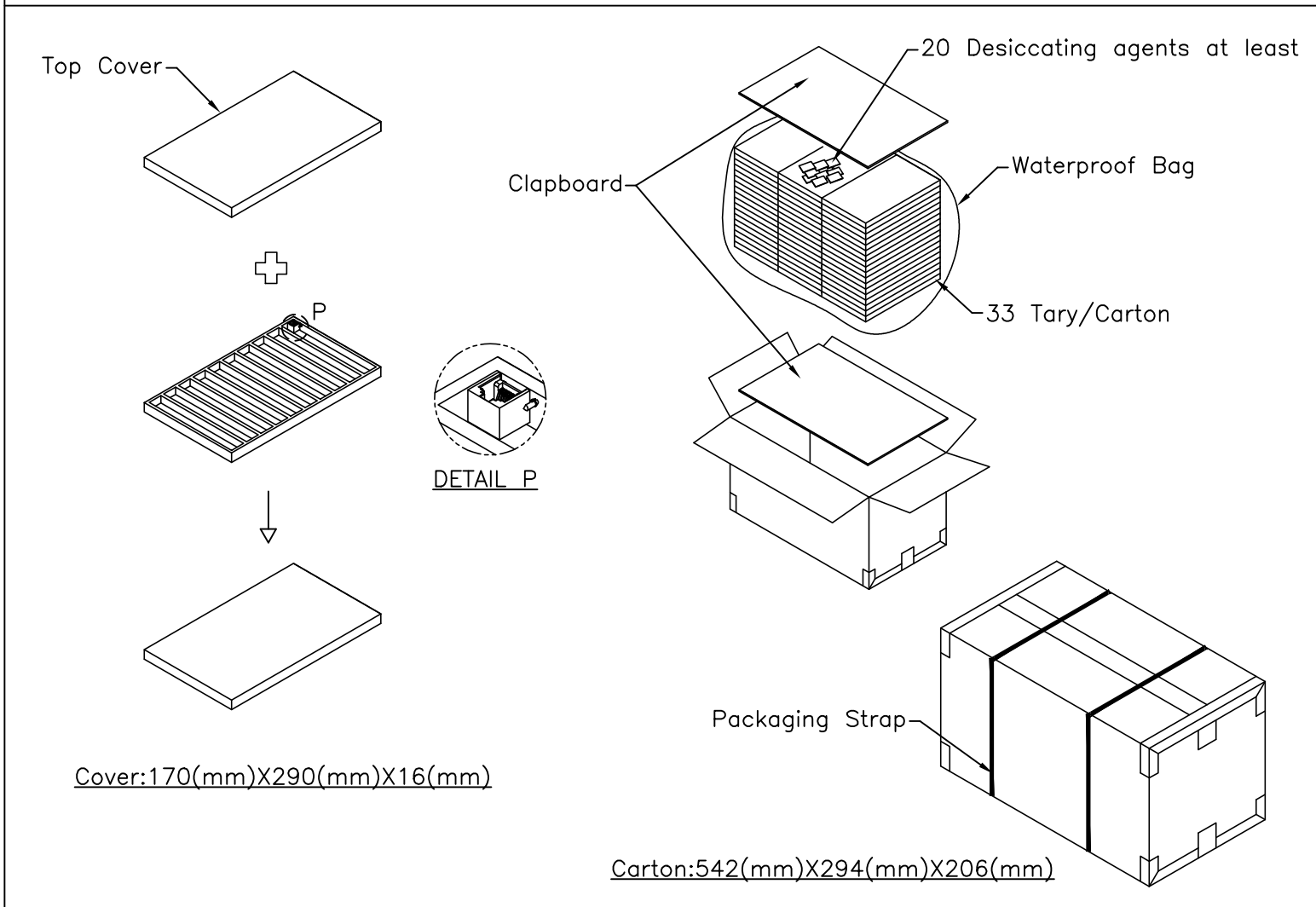

**Package:**  
 90 Pcs/ Tray  
 33 Tray/ Carton  
 2970 Pcs/ Carton

N.W. : 10.9 kg  
 G.W. : 11.9 kg

Drawn By: Sherry 06/17'19