

歐品電子(昆山)有限公司

OUPIIN ELECTRONIC(KUNSHAN) CO.,LTD.

PACKAGING SPECIFICATION (包裝作業規範)

SPEC.NO.(規範編號)	8949SPP-F11010	適用產品: 8949-F11010-06YNA	PAGE	1/1	REV.	I563-A1
----------------	----------------	-------------------------	------	-----	------	---------

PACKING OPERATION DIAGRAM & INSTRUCTION (包裝作業圖示及說明)	REMARK (備註)
---	-------------

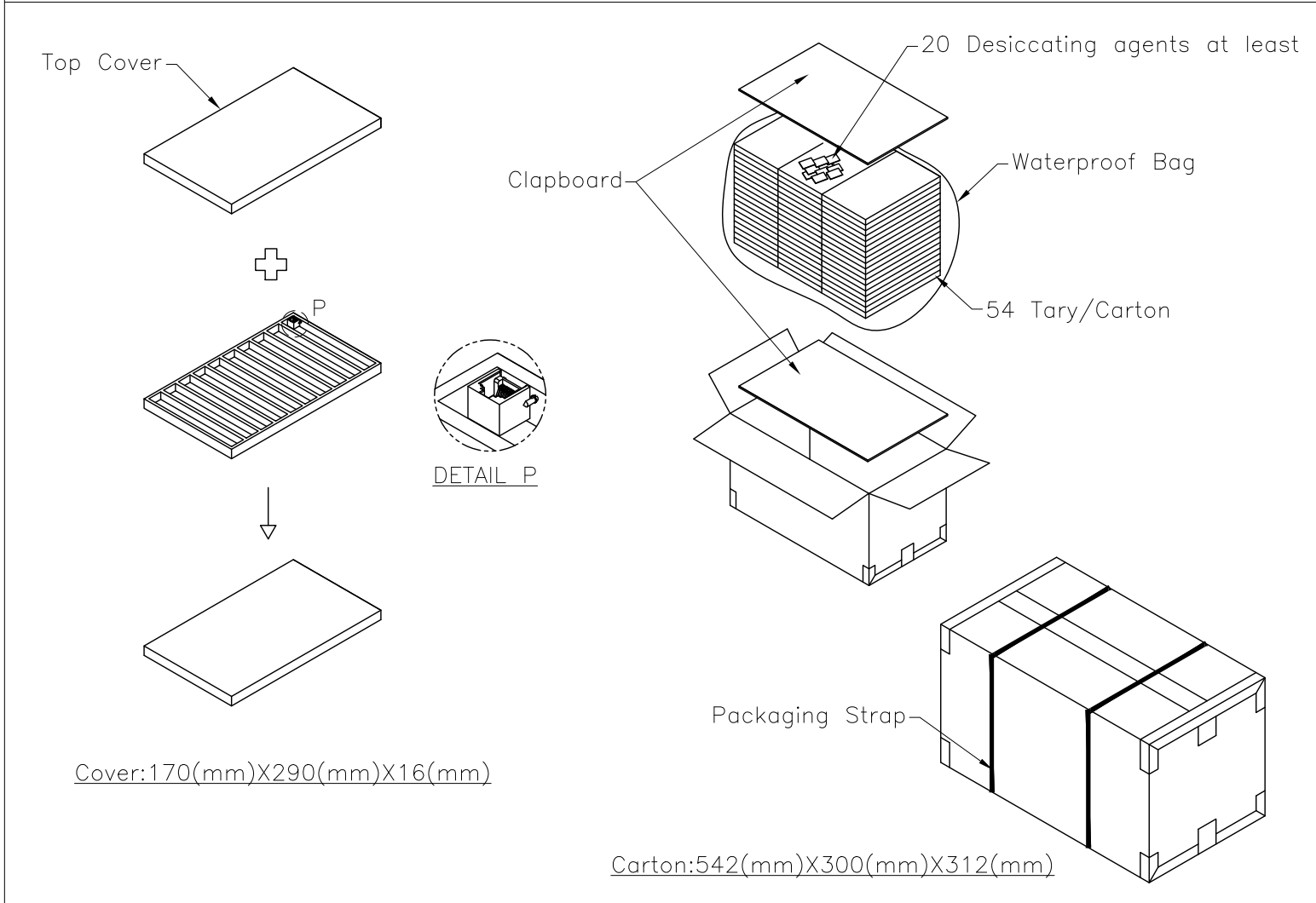

Package:
 90 Pcs/ Tray
 54 Tray/ Carton
 4860 Pcs/ Carton

N.W. : 9.9 kg
 G.W. : 14.9 kg

Drawn By: Doris 08/21'18