

REV.	SPECIFICATION	ECN NO.	APPD.

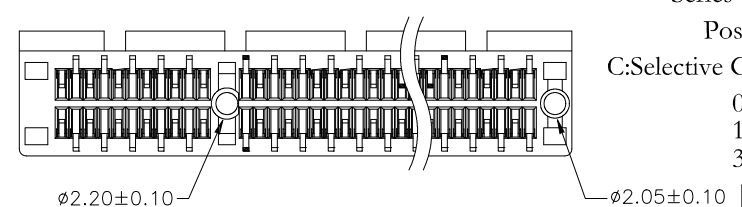
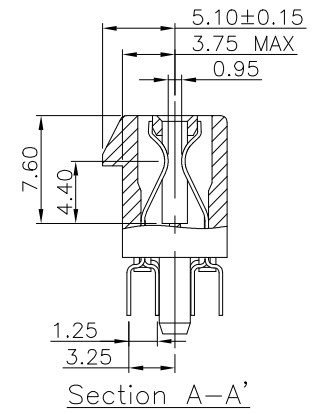
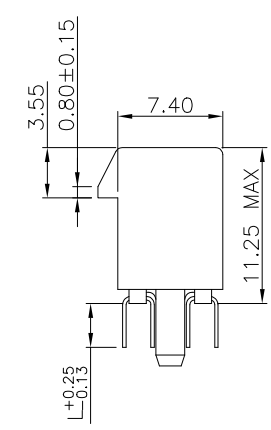
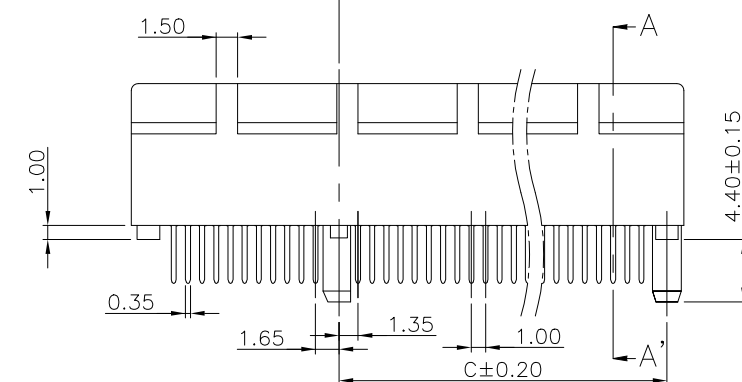
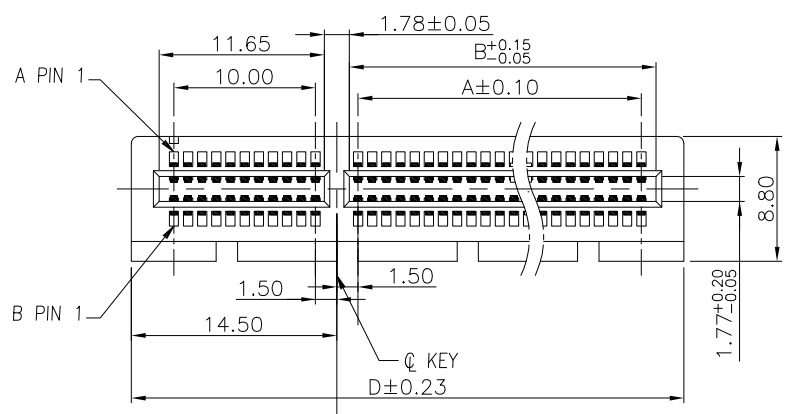

8406-C xx C 00 S -2.3 A

Series: 8406-C
 Positions: xx
 C: Selective Gold Plated
 00: Gold Flash
 15: 15u"
 30: 30u"

S: Straight
 -2.3: L for 2.3
 Blank: L for 3.1
 A: Tray Package

Material:
Housing: PA9T, UL94V-0, Black.
Contacts: Phosphor Bronze, Gold Plated on Contact Area and 100u" Matte Tin Plated on Solder Tail Area over 50u" Nickel.

Electrical Characteristics:
 Current Rating: 1.1A.
 Dielectric Withstanding Voltage: AC 500V.
 Insulation Resistance: 1000MΩ min.
 Contact Resistance: 30mΩ max.
 Operating Temperature: -40°C~+85°C.
***RoHS Compliant**

DIMENSIONS				
POSITION	A	B	C	D
36	6	7.65	9.15	25.00
64	20	21.65	23.15	39.00
98	37	38.65	40.15	56.00
164	70	71.65	73.15	89.00

Tolerances	Dwg. No.	S1820230621-01		Title:	8406-C Series	
x. = ±0.40	Projection	⊕ ↯			PCI Express	
.x = ±0.30	Unit	mm	Scale	1:N	Pitch 1.0mm	
.xx = ±0.20	Drawn By	Martin 06/21'23		Ⓟ 716	Straight Type	
.xxx = ±0.10						

8406-C Series
 PCI Express
 Pitch 1.0mm
 Straight Type

OUPIN
 OUPIN ELECTRONIC(KUNSHAN) CO., LTD.
 P/N: 8406-CxxC00S-2.3A

SHEET	1/3	Ver.No.	X1
-------	-----	---------	----

REV.	SPECIFICATION	ECN NO.	APPD.

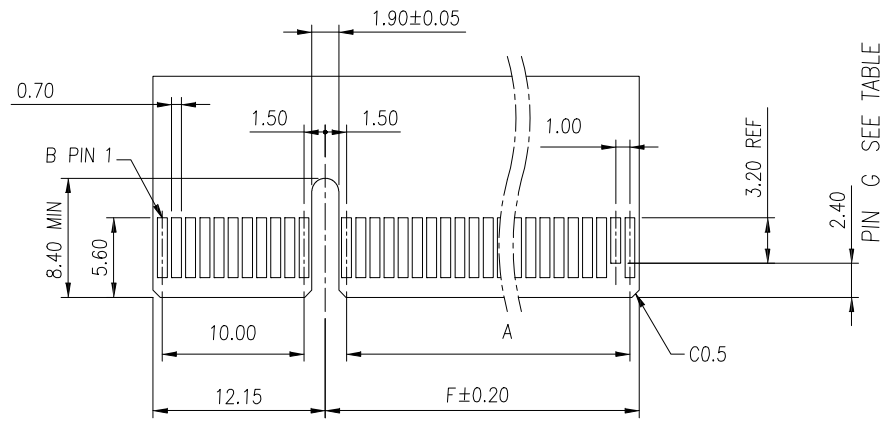

I/O PANEL DIRECTION
PRIMARY (COMPONENT) SIDE

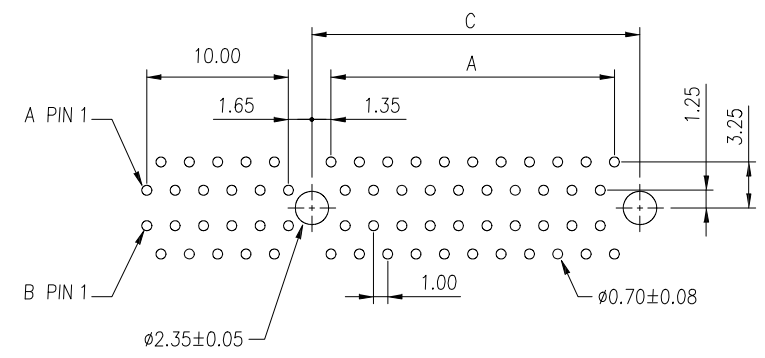

RECOMMENDED PCB LAYOUT
TOLERANCE: ±0.05

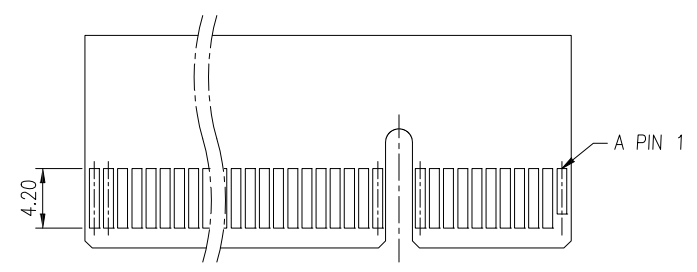
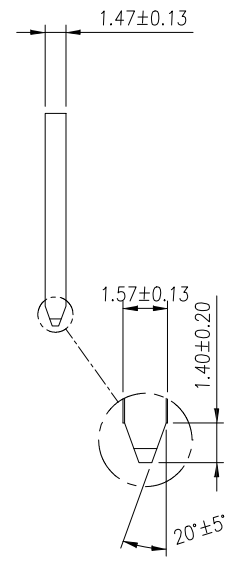

I/O PANEL DIRECTION
SECONDARY (SOLDER) SIDE
ADD-IN CARD EDGE-FINGER DIMENSIONS

POSITIONS	DIMENSIONS			
	A	C	F	G
36	6	9.15	8.15	B PIN 17
64	20	23.15	22.15	B PIN 31
98	37	40.15	39.15	B PIN 48
164	70	73.15	72.15	B PIN 81

Tolerances	Dwg. No.	S1820230621-01
x. = ±0.40	Projection	
.x = ±0.30	Unit	mm
.xx = ±0.20	Scale	1:N
.xxx = ±0.10	Drawn By	Martin 06/21'23

Title: 8406-C Series
PCI Express
Pitch 1.0mm
Straight Type



OUPIIN
OUPIIN ELECTRONIC(KUNSHAN) CO., LTD.
P/N: 8406-CxxC00S-2.3A

SHEET	2/3	Ver.No.	X1
-------	-----	---------	----

716

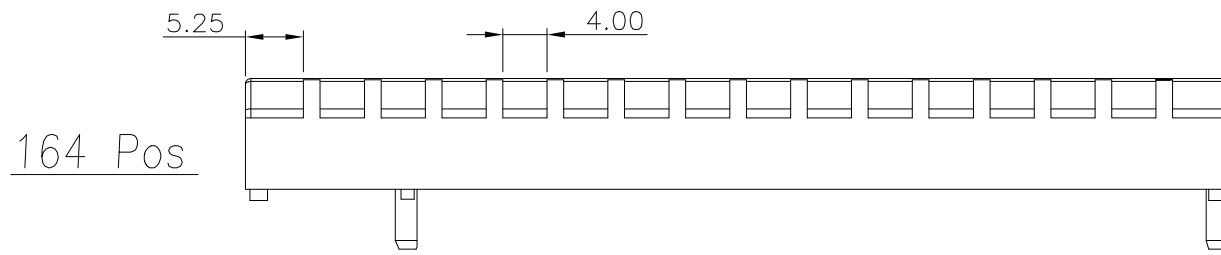
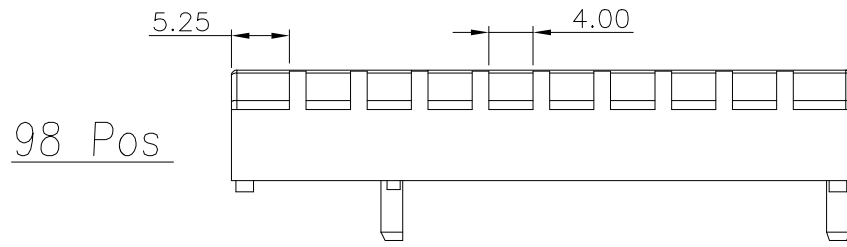
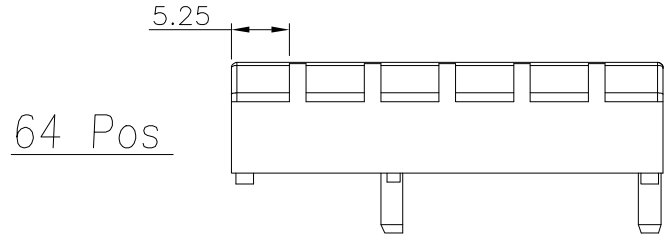
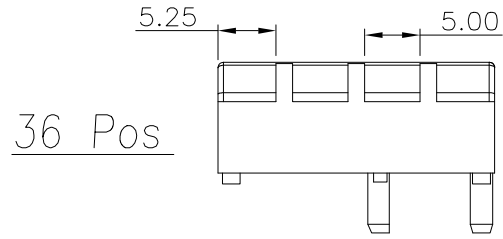
REV.	SPECIFICATION	ECN NO.	APPD.



Tolerances x. = ±0.40 .x = ±0.30 .xx = ±0.20 .xxx = ±0.10	Dwg. No.	S1820230621-01		Title: 8406-C Series PCI Express Pitch 1.0mm Straight Type	 OUPIIN ELECTRONIC(KUNSHAN) CO., LTD. P/N: 8406-CxxC00S-2.3A	
	Projection					
	Unit	<i>mm</i>	Scale			1:N
	Drawn By	Martin 06/21'23				① 716
SHEET		3/3	Ver.No.	X1		