

REV.	SPECIFICATION	ECN NO.	APPD.
------	---------------	---------	-------

Material:
Housing: PBT, UL94V-0.
Contacts: Phosphor Bronze, Gold Plated on Contact Area and Gold Flash on Solder Tail over Nickel 50u".
Shell: Brass, Nickel Plated.
Electrical Characteristics:
Current Rating: 1.5 AMP.
Dielectric Withstanding Voltage: AC 1000V.
Insulation Resistance: 500MΩ min.
Contact Resistance: 30mΩ max.
Operating Temperature: -40°C~+85°C.
***RoHS Compliant**

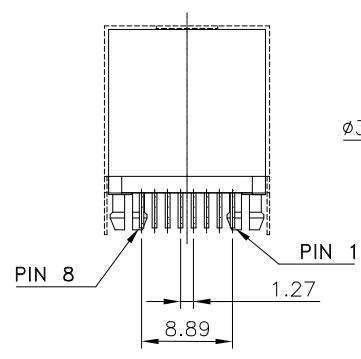
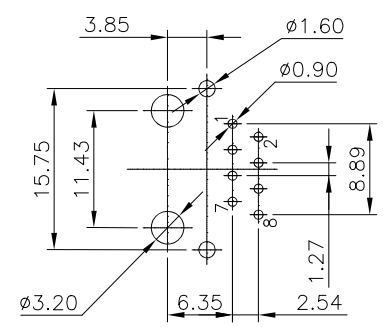
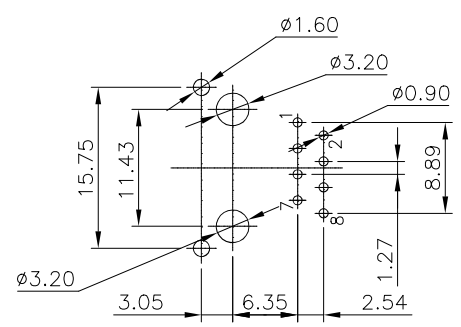
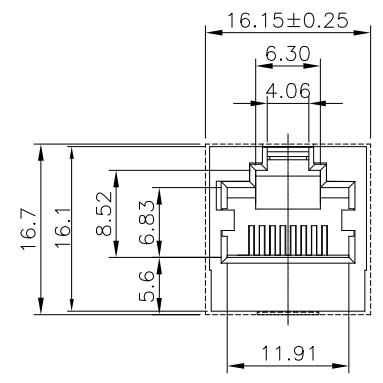
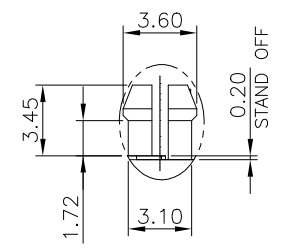
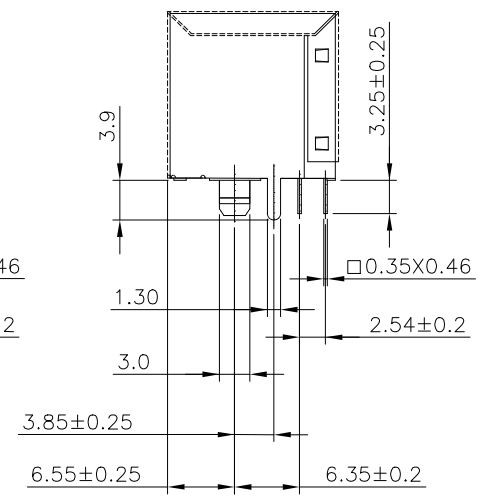
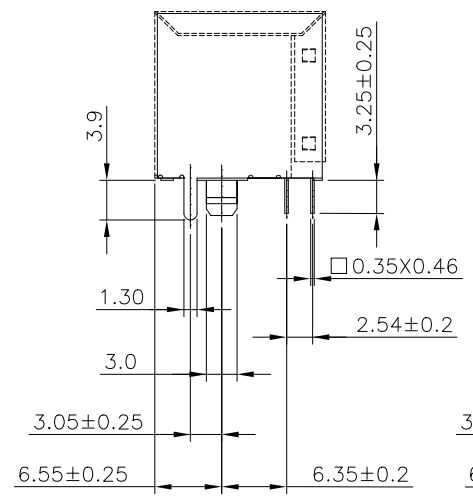
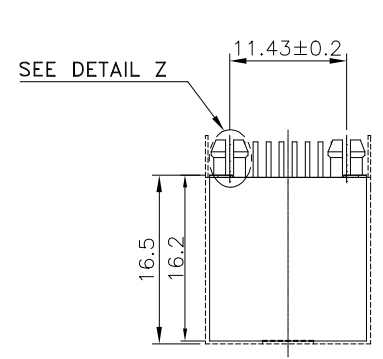

PCB LAYOUT
PCB THICKNESS: 1.6±0.05mm
SD0 Type

PCB LAYOUT
PCB THICKNESS: 1.6±0.05mm
SE0 Type

Series: 8949-H1
8: 8 Position
8: 8 Contacts
6: 6 Contacts
4: 4 Contacts
2: 2 Contacts

-06: 06u" Gold Plated
-15: 15u" Gold Plated
-30: 30u" Gold Plated
-50: 50u" Gold Plated

A: Tray Package
B: Black
R: Red
SD0: SD0 Type
SE0: SE0 Type
Blank: Non - Shield

Tolerances .x = ±0.25 .xx = ±0.13 .xxx = ±0.05	Dwg. No.	8949D02117		Title: 8949-H1 Series Modular Jack Without LED CAT 5e	 DUPIN ELECTRONIC(KUNSHAN) CO., LTD.				
	Projection								P/N: 8949-H188-06Sx0BA
	Unit	mm	Scale		1:1	SHEET	1/1	Ver.No.	
	Drawn By	Martin 02/24'22			① 563				